

Technology and
guarantee for the
construction industry

 **GARCIA FAURA**
ARCHITECTURE
IN ALUMINUM,
STEEL AND GLASS

GARCIA FAURA
ARCHITECTURE
IN ALUMINUM,
STEEL AND GLASS

We are delighted to present **GARCIA FAURA**, a pioneering company in the development of glass facades, curtain walling and aluminium and glass window and door solutions. We are a family company of international scope, founded in 1888, with headquarters in Gavà (Barcelona) and branches in **Colombia and France**.

The aim of this catalogue is to provide valid reasoning for you to instil your trust in us, taking into account our technical and productive skills, as well as the history, financial health and guarantee of the market-leading company in terms of leadership and quality.

We are able to make all types of designs, needs and projects become a reality, equipped with state-of-the-art machinery and an expansive team of professionals working on all sorts of construction projects; from those that seem to be more simple to those of great magnitude.

We are convinced we are the best option for your requirements, and we will be delighted to embark on your construction projects with you. Will you let us share your journey? Welcome to **GARCIA FAURA**.



DOW CORNING

Quality Bond



Visit
GARCIA FAURA
on video

Scan this
QR code



Proximity leadership

We are proud to offer what we call proximity leadership: the potential of a leading company with a close and direct service.

Our most genuine humbleness does not prevent us from proudly recognising the leading role played by **GARCIA FAURA** across the territory. This is because it is the result of the drive, effort and commitment of dozens and dozens of professionals who work so hard at a job about which they are passionate. It is because we believe in what we do and we fight every day to continue planning towards the future.

We have more than 125 years of experience and thousands of projects under our belt. The guarantee of an outstanding team and of state-of-the-art installations and machinery.

A way of being and doing that we bring with us wherever we go. When **GARCIA FAURA** joins a new market, it does so with the will to comply with its Corporate Social Responsibility policy. This involves understanding the market in which we are working, becoming familiar with its procedures, and committing to and supporting our customers. Because we understand our dealings with construction companies and developers as a relationship of commitment and trust, and not simply as a contract between a customer and a supplier.

STAFF DEVELOPMENT

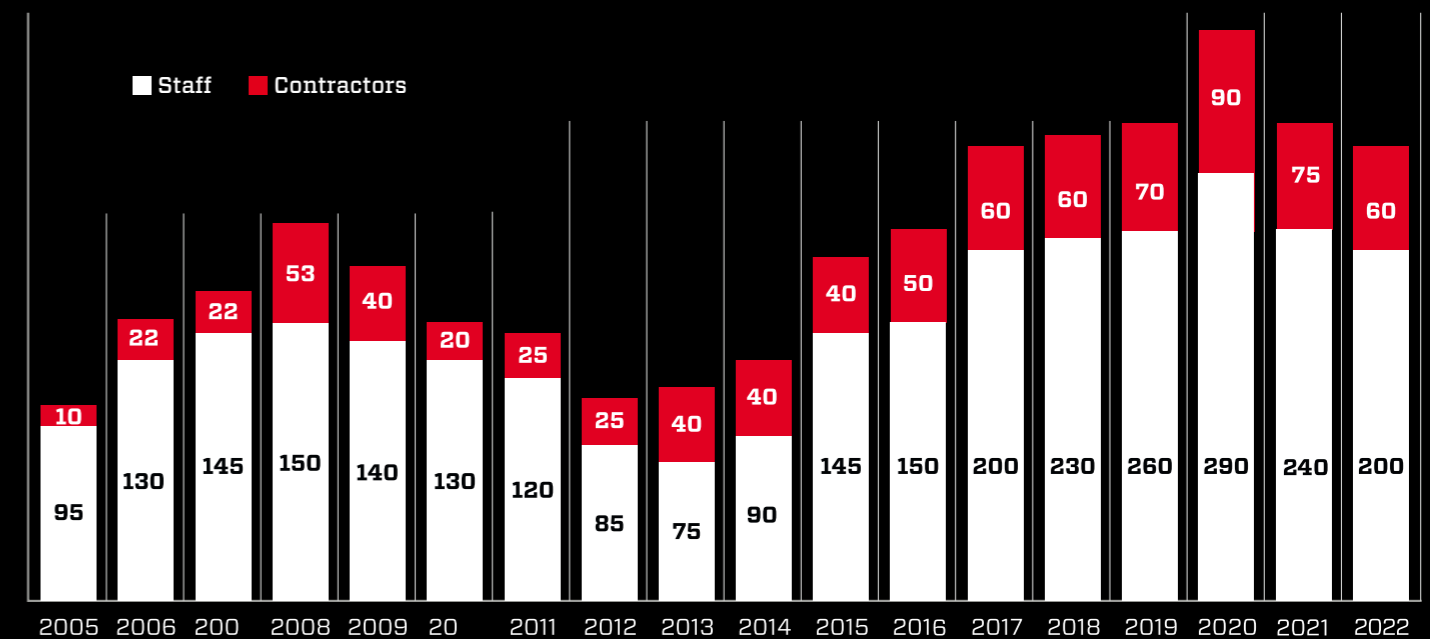

A national company of international scope

GARCIA FAURA was founded in Gavà (Barcelona) and, after becoming a leading company in the region, we expanded to join the international market. As a result of our ability to develop and our desire to grow, we have become a leading company in the countries in which we have branches.

We achieved this by transferring, above all, business capital, technical skills and human potential. Because if the model that GARCIA FAURA has always upheld worked at home, why should we give it up when we go abroad?

Committed to the territory and to its people

Just as we want to commit to the local economy of the location in which we are working. That is why we want to promote the hiring and training of local people and support the installation of the maximum number of services in the actual place where we are working. That is our way of being and of working, and we are proud of it.

TURN OVER IN MILLIONS OF €

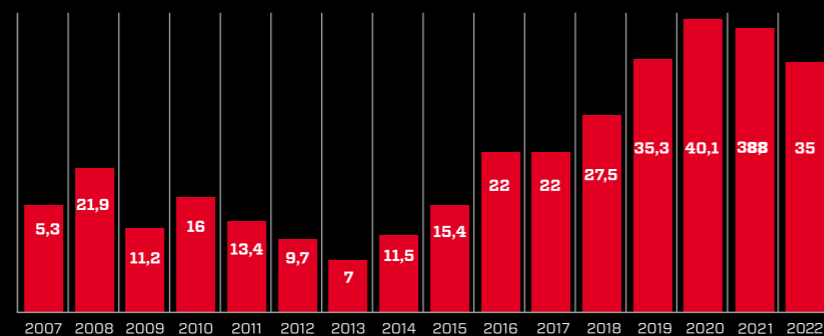

GARCIA FAURA executes projects in different countries in Europe and America. The volume of international projects represents 40% of the total annual turnover of the company



Territorial presence in the countries of operation

HEADQUARTERS IN GAVÀ

16.000 m² of facilities.

Headquartes of the technic areas, production, quality, commercial, administration and inner services.

Production area and specific workshops for Aluminum, Steel and Sheet.

DELEGATION IN MADRID

Technic and commercial areas, and representation for the central area of Spain.

DELEGATION IN FRANCE

Commercial and administration offices and representation for the whole Spanish territory.

DELEGATION IN COLOMBIA

Technical area, commercial and administrative delegation.

The main technical department for the sector

This is **GARCIA FAURA's** technical department.

Under the coordination of a highly qualified technical management team, the company has 40 engineers and architects distributed across the different branches of the company, specifically trained in the development of facades and window and door solutions. Over the past three years, this team has grown at a rate of 40% per year, turning **GARCIA FAURA** into the company in the sector with the greatest in-house technical skills.

A constantly evolving team

- ◆ Implementation of new facade design, management and development programmes.
- ◆ Continuous specialised training.
- ◆ Internal work groups that design continuous improvement strategies.
- ◆ Work and training sessions given by renowned experts in the application of the product (facades, profiles, glass works, etc.).

Discover the
GARCIA FAURA's
Technical department

Scan this
QR code

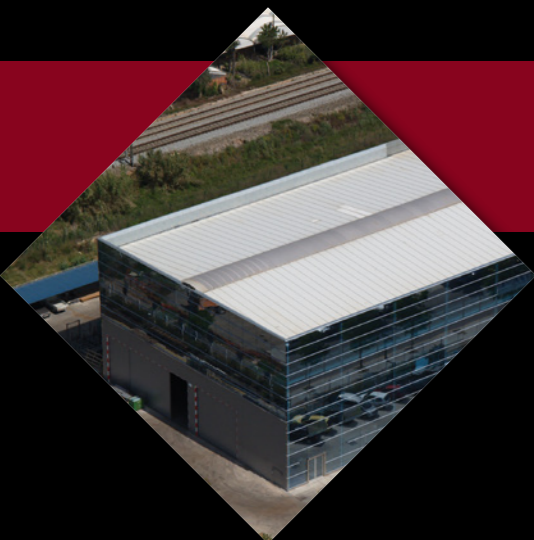

High productive capacity

The **GARCIA FAURA** production centres are designed as flexible work spaces, designed to adapt to the specific production needs and assembly lines for each site.

With a permanent team of more than 60 first-rate officials, and the organisational capacity required to modulate the increase of resources according to the rate of production. This is with a tightly structured work schedule that still affords the flexibility required to meet everyday needs.

Would you like to see
how is organised the
productive area of
GARCIA FAURA?

Scan this
QR code



An outstanding track record

Every year **GARCIA FAURA** carries out more than one hundred construction projects in the different countries where it is present. The majority of these are characterised by their high level of technical specialisation and their unique approach. A track record that meets the expectations that our customers have of us.

In addition to our historic and renowned reputation in the production and installation of aluminium window and door solutions, we also have more than 15 years of continued and current experience in the development of modular facades. Our organisation and production structure model serves to simultaneously carry out different projects on the facade.

Would you like to see how our modular facade development workshop operates?

Scan this QR code



Guarantee of peace of mind

GARCIA FAURA was one of the first companies in its sector to be awarded the ISO 9001 standard, an international standard that guarantees the maintenance of a comprehensive quality management. Not only in the production phase, but in all the business processes.

The **GARCIA FAURA** Quality Management Manual also includes in-factory production control that encompasses all the internal inspection points that are established to guarantee the correct production of all the company products and materials. There is also assembly control that certifies the correct performance of the contracted work.

The company has installed all the work processes required for this type of facade. The owner and the construction company can access the projects we are carrying out whenever necessary.

Not only that; our main aluminium suppliers also have the ISO 9001 standard. A double guarantee of quality based on international standards.

At **GARCIA FAURA** we are so convinced of our levels of quality in the in-factory production control, that we undertake to provide the owner or the construction company with access to our production installations at any time during the process, during work hours and on all work days, thus enabling them to be present in all the production processes.

Quality vouched for by our customers

The quality, solvency and professionalism of **GARCIA FAURA** is backed up by the opinion of our customers. We believe the satisfaction of the end users of the buildings we build is as important as that of the site managers responsible for the entire construction process in which we participate. The opinion of the latter represents the guarantee of trusting in a company that not only fulfils its promises, but also offers all the elements of satisfaction required for the correct execution of a project.

Results of a satisfaction survey conducted with team leaders and site managers from the construction companies for which we work*:

Evaluation of sales and technical attention received before and during the execution of the project

8,5

Ability of the global evaluation managers to solve any need presented during the execution

9,15

Global evaluation with the site service to solve any need presented by **GARCIA FAURA**

8,5

Result of the satisfaction survey on the after-sales service of the company in completed projects*:

Evaluation of the sales and technical attention received before and during the execution of the project

8,75

Ability of the after-sales team to solve any need or complaint

8,75

Global evaluation with the service provided by the **GARCIA FAURA** after-sale service

8,5

* Average rating on a scale of 0 to 10 according to the data collected in the last annual satisfaction survey carried out with our clients.



Technology for your projects

We have specialised machinery and specific software for the manufacturing of all the materials we provide, with an annual investment policy designed to continue being leaders in the handling of aluminium, iron, stainless steel and glass.

1 CNC EMMEGI QUADRA L2 double head cutting saw.

1 EMMEGI PRECISIONS RS600 double head CNC cutting saw (DISC Ø600mm), with profile height meter, label printer, minimum lubrication system and chip conveyor belt.

1 TEKNA TK 145/20 CNC double head cutting saw with profile height meter, label printer, minimum lubrication system and chip conveyor belt.

1 TEKNA TK 145/10 double head cutting saw.

1 TEKNA 427/8 machining center with automatic tool changer and double work area.

1 EMMEGI SATELLITE XT vertical machining centers with vertical mandrel and 5-axis CNC movable upright.

2 EMMEGI COMMET 6 machining centers with 4 CNC axes for machining bars up to 7.7 m.

1 Machining centre TEKNA 427/8 automatic tool changer and double work zone.

1 Machining centre MECAL MC302 GEOS-5 with vertical mandrel and 5-axis mobile pillar CNC.

1 BIESSE ROVER PLAST B FT machining center for panels.

2 Vertical panel saws ELCON 215 DS.

2 AJIAL CS630 pendulum cutting hydraulic shears.

1 ZS pendular cutting hydraulic shear.

1 SCHRODER Multi PowerBend3200x2 CNC bending machine.

1 AJIAL PPH909 hydraulic folding press of 90 Tn.

1 120 Tn BLECKEN hydraulic folding press.

2 Copiers (1 double head).

2 Assemblers (miter saws).

2 Gluing machines.

2 ATIS glass weightless manipulators.

Assembly, glazing and verification benches.

Vertical packing machines.

MECAL steel cutting machines.

Semi-automatic FAT steel cutting machines.

Pneumatic suction cups for handling glass up to 1,000 kg.

Steel punching machines and presses.

Customers who already trust in GARCIA FAURA

Local and multinational construction and development companies have trusted in **GARCIA FAURA** for years. The result of this trust are the hundreds of buildings that we have built together.

And most importantly: the satisfaction of having contributed to the development of global architecture and the day-to-day wellbeing of the occupants of houses, hotels, public installations and corporate businesses.

Thank you for helping us to make it happen!

sacyr

vopi
constructora

DRAGADOS



FCC

CATALONIA
- HOTELS & RESORTS -

ferrovial

VINCI
CONSTRUCTION

SOLUDEC

SB hotels

acciona

CALAF
CONSTRUCTORA

ABL GROUP

soriguē

REM
CONSTRUCCIONES

COMSA
CORPORACIÓN

IBERDROLA
Inmobiliaria

VIAS

NÚÑEZ I NAVARRO

copcisa

Agbar
suez
environnement

OIC | PENTA

elecnor

The image features a modern building facade with a grid of windows and a red diamond-shaped graphic overlay. The text "GARCIA FAURA PROJECTS" is centered within the red diamond in a white, bold, sans-serif font. The background is a dark, low-angle shot of a building with a grid of windows and a red diamond-shaped graphic overlay.

**GARCIA FAURA
PROJECTS**



MÚTUA DE TERRASSA UNIVERSITY HOSPITAL

Terrassa (Spain)

GARCIA FAURA
ARCHITECTURE
IN ALUMINUM,
STEEL AND GLASS

MÚTUA DE TERRASSA UNIVERSITY HOSPITAL
Terrassa (Spain)



Year of completion
2017

Architect
Duran Arquitectes

Works surface area
Enclosures: 702 m²
Glazed partitions: 300 m²

The Mutua Terrassa University Hospital, located in the town centre, is undergoing expansion through the acquisition of adjoining buildings. On this occasion, a new building housing the external consultancy, rehabilitation and Contact Centre services has been constructed. A large glazed walkway underneath the Vallparadís bridge connects the new buildings to the existing complex. This element opens onto a large elevated balcony looking out over the park. A vertical communications hub has also been constructed, with escalators and lifts serving to connect plaza de los Derechos Humanos with the new medical departments at Mutua.

For this project, **GARCIA FAURA** fabricated and installed almost 700 m² of exterior facade enclosures offering high levels of thermal and acoustic insulation performance, in pursuit of attaining the maximum requirements of a hospital department with such specifications. Works also comprised a set of interior enclosures in addition to 300 m² of glazed partitions installed over stainless profiles.

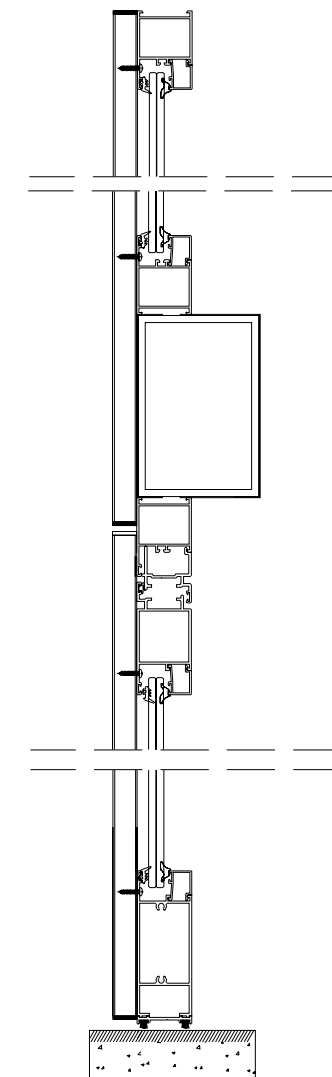

GARCIA FAURA
ARQUITECTURA
EN ALUMINI, INOX
FERRO I VIDRE



TURÓ DE LA PEIRA MUNICIPAL SPORTS CENTRE

Barcelona (Spain)

GARCIA FAURA
ARCHITECTURE
IN ALUMINUM,
STEEL AND GLASS

TURÓ DE LA PEIRA MUNICIPAL SPORTS CENTRE
Barcelona (Spain)



Year of completion
2018

Architect
Anna Noguera & Javier Fernández

Works surface area
Curtain wall: 750 m²
Railings: 50 m length
Balustrade cladding: 120 m length
Interior doors: 4 units
Glazed skylight: 1 unit

The entire space has been designed in accordance with sustainability criteria. The building structure is timber due to its light weight and suitability for the swimming pool environment. A vertical garden has been added, which provides solar protection and promotes biodiversity. The building is also equipped with solar collector and photovoltaic panels in addition to an arothermal air conditioning system. The swimming pool is located on the ground floor of the new building and an exterior ramp connects directly to the upper floor of the multisports centre, which is surrounded by latticework in which greenery grows.

The work undertaken by **GARCIA FAURA** provided the building with a curtain wall, working towards achieving the principal project requirement set by the team of architects: making the installation a benchmark of sustainable architecture. The facade that was developed comprises parallel and Italian-style windows with high technical performance aluminium profiles. All of this has made the building into an example of responsible construction. This has already been made official by the building being awarded various prizes, such as the 2019 Premio Mapei award for sustainable architecture.

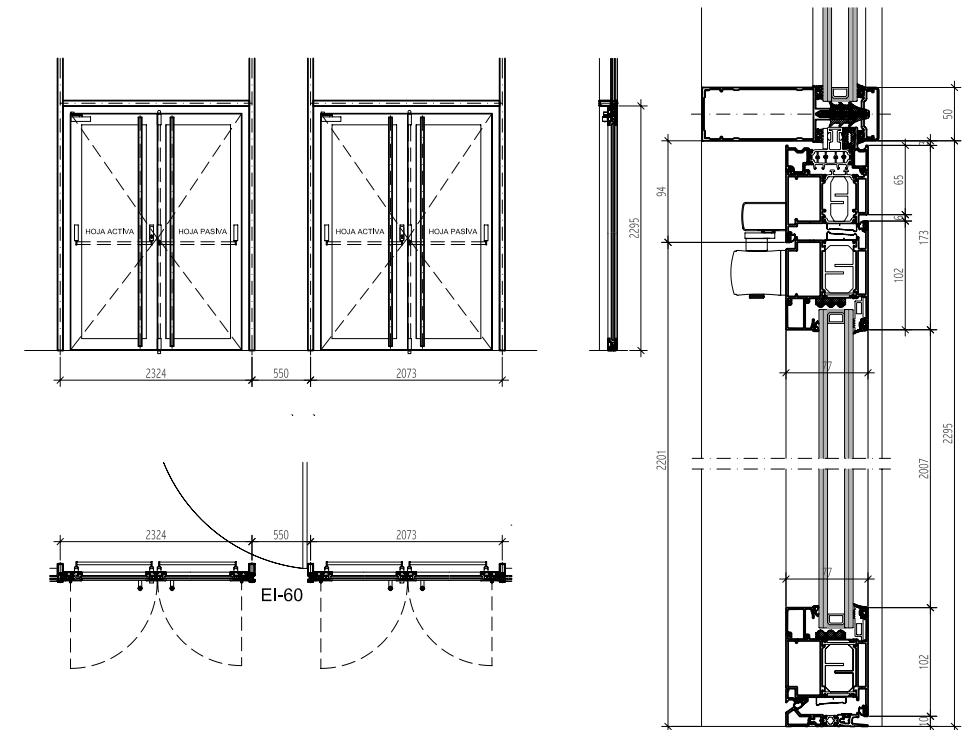

GARCIA FAURA
ARQUITECTURA
EN ALUMINI, INOX
FERRO I VIDRE



PARADOR AIGUABLAVA

Begur (Spain)

GARCIA FAURA
ARCHITECTURE
IN ALUMINUM,
STEEL AND GLASS

PARADOR AIGUABLAVA
Begur (Spain)



Year of completion
2018

Architect
GCA Arquitectes

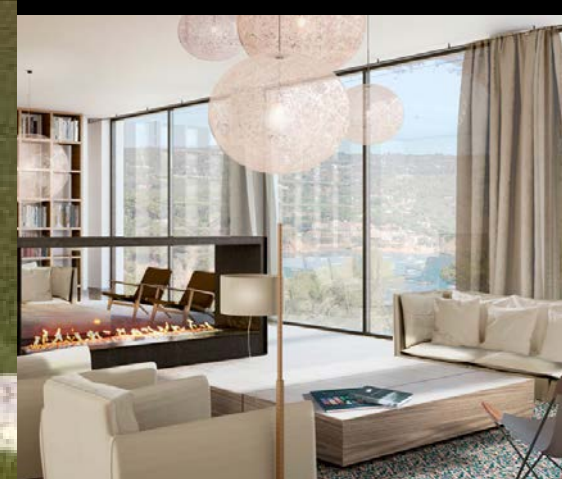

GARCIA FAURA
ARQUITECTURA
EN ALUMINI, INOX
FERRO I VIDRE

Parador de Aiguablava is a four-star hotel which first opened its doors in 1934, right in the heart of the Costa Brava. It is flanked by crystal-water coves and golden beaches, with enchanting towns such as Pals or Tamariu. With over 80 years of history, the establishment has undergone a profound renovation with the aim of bringing installations up-to-date and modernising its spaces, to welcome in a new benchmark stage for the Costa Brava tourism sector.

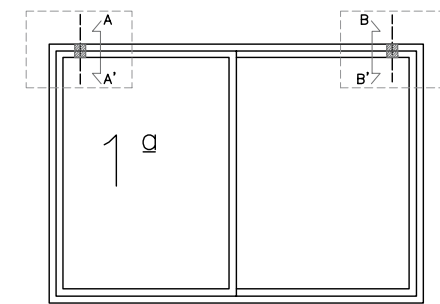

Sección B-B'

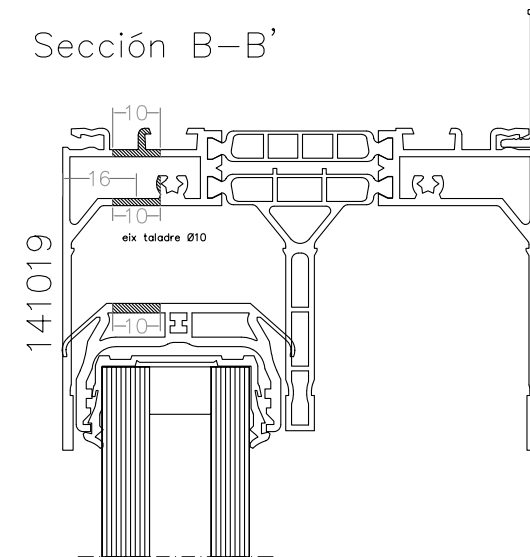

Sección A-A'

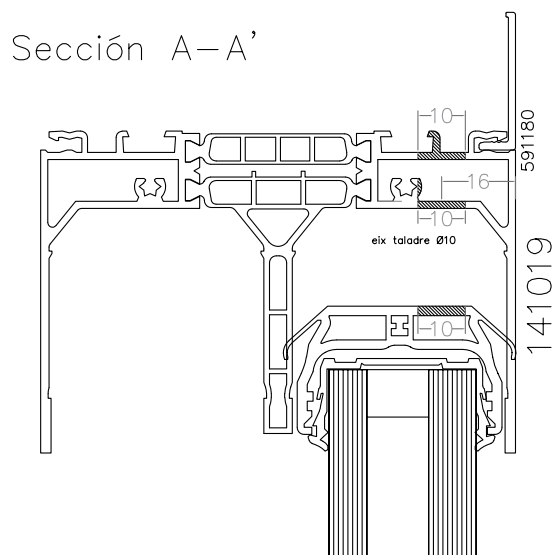



TRYP BARCELONA APOLO HOTEL

Barcelona (Spain)

GARCIA FAURA
ARCHITECTURE
IN ALUMINUM,
STEEL AND GLASS

TRYP BARCELONA APOLO HOTEL
Barcelona (Spain)



Year of completion
2017

Architect
Mur Arquitectura

The four-star hotel spans nine floors with over 300 rooms and was constructed in 1992 on the avenida del Paralelo, in the nerve centre of the Catalan capital in terms of economic, commercial and touristic activity. Indeed, the building is a ten-minute walk from the exhibition centre and Palau de Congressos, and is just a ten-minute drive from the Sagrada Familia.

The hotel has undergone extensive integral restructuring, with **GARCIA FAURA** being entrusted with the development, fabrication and installation of a set of exterior enclosures for the establishment. This was achieved through the use of aluminium profiles with thermal bridge break and high levels of technical performance, thus increasing the level of comfort in the rooms.

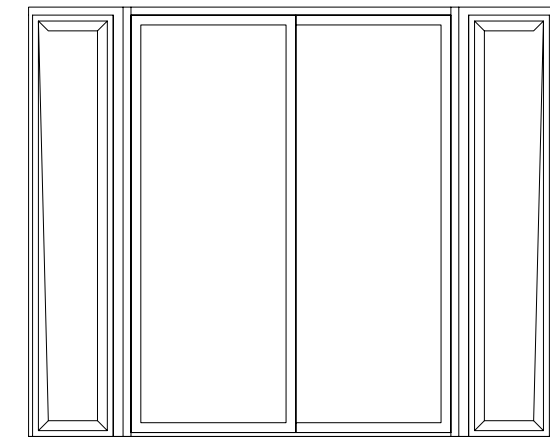

Carpintería corredera con fijos laterales

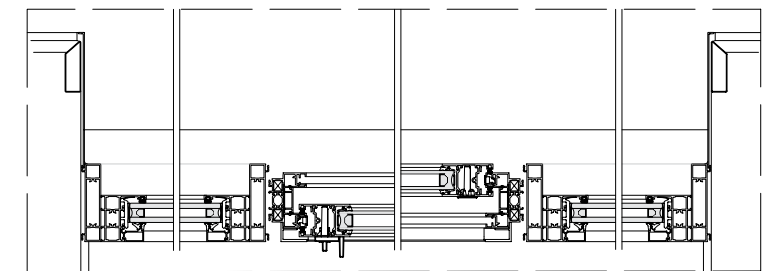

D.14
Sección horizontal

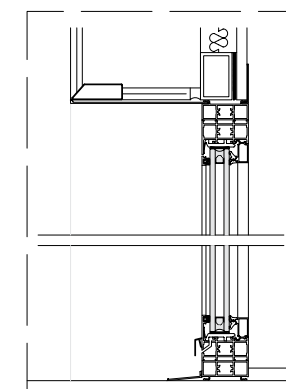

D.14
Sección vertical

GARCIA FAURA
ARCHITECTURE
IN ALUMINUM,
STEEL AND GLASS



MAPFRE TOWER RENOVATION

Barcelona (Spain)

GARCIA FAURA
ARCHITECTURE
IN ALUMINUM,
STEEL AND GLASS

MAPFRE TOWER RENOVATION
Barcelona (Spain)



Year of completion
2017

Architect
CBRE

Works surface area
Curtain wall: 480 m²
Facade cladding: 2400 m²
Glazed cladding: 850 m²
Interior enclosure over iron structure: 162 m²
Cornice: 158 m²
Composite cladding: 165 m²

Remodelling of an iconic city building constructed in 1992 and located in the Olympic Village zone, on the sea front in the Sant Martí district. Standing 154 metres high and covering 40 floors, it is one of the highest skyscrapers in Catalunya. The ground floor houses a shopping centre and the remaining floors are home to offices, the majority of which are owned by the insurance company after which the tower is named.

480 m² of aluminium curtain walling were installed by **GARCIA FAURA** in the building's entrance facade, in addition to 2400 m² of double-skin walling, printed glazing and facade cladding for the first four floors, incorporating a new extrusion system that was especially designed for this project. Almost 850 m² of glass panel cladding have been installed in the tower foundation interior area. It is also worth noting the solution implemented for the corncing, which presented a certain amount of complexity, as well as the interior glass panel enclosure with a chamber constructed over an iron structure.

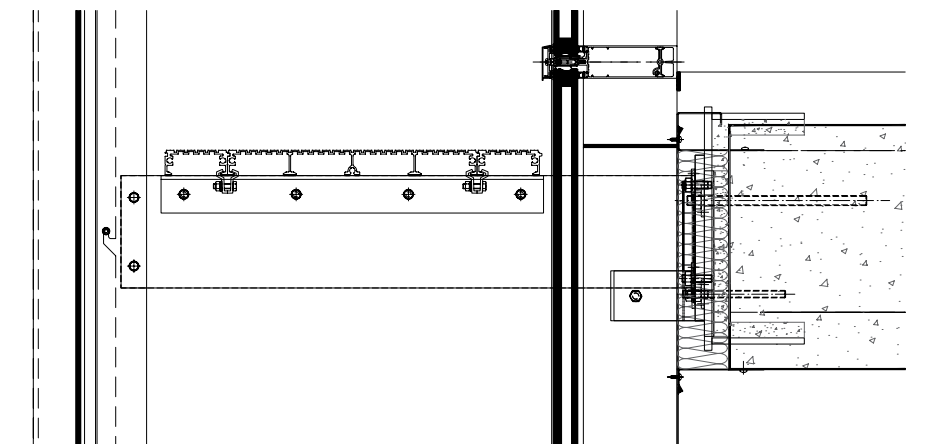
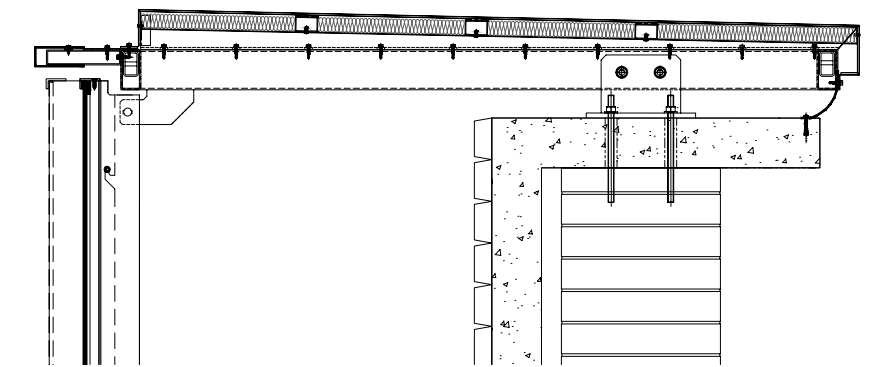

GARCIA FAURA
ARCHITECTURE
IN ALUMINUM,
STEEL AND GLASS



EASYHOTEL L'HOSPITALET

L'Hospitalet de Llobregat (Spain)

GARCIA FAURA
ARCHITECTURE
IN ALUMINUM,
STEEL AND GLASS

EASYHOTEL L'HOSPITALET
L'Hospitalet de Llobregat (Spain)



Year of completion
2018

Architect
Corada - Figueras

Works surface area
Enclosures: 332 units
UPN: 1015 m length
Deployé Panels: 2350 m²
Banners: 400 units
Canopy: 44 ml

The first easyHotel in Spain is a one-star hotel, covering ten floors and boasting 204 rooms. There are also communal areas, an interior garden, terrace and underground car park. The building blends into the local urban landscape while maintaining its own character.

GARCIA FAURA fabricated and installed 332 opening concealed leaf windows with a black anodised finish, in addition to installing gold finish "deployé" panels on the exterior, bonded to UPN-type surround lintels at the framework edges, also gold in colour. Finally, the company installed the ground floor canopy, also incorporating gold "deployé" panels.

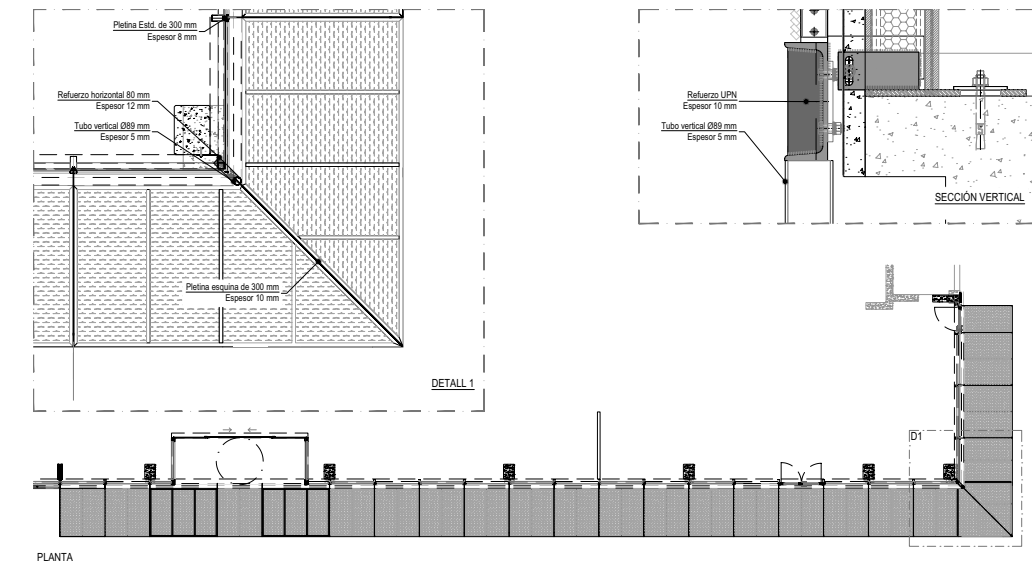
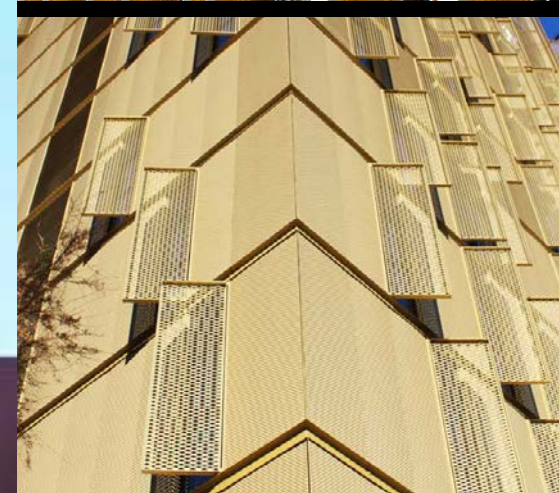
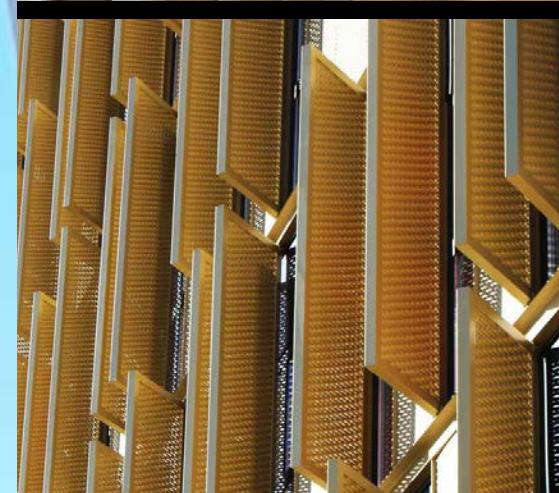

GARCIA FAURA
ARCHITECTURE
IN ALUMINUM,
STEEL AND GLASS



TERRASSA FUNERAL PARLOUR

Terrassa (Spain)

GARCIA FAURA
ARCHITECTURE
IN ALUMINUM,
STEEL AND GLASS

TERRASSA FUNERAL PARLOUR
Terrassa (Spain)



Year of completion
2018

Architect
Batlle i Roig Arquitectes

Works surface area
Enclosures: 275 m²



GARCIA FAURA
ARCHITECTURE
IN ALUMINUM,
STEEL AND GLASS

The Terrassa Municipal funeral parlour building has a minimalist design comprising all of the necessary details to ensure that families feel welcomed. There is a great deal of natural light and the building is surrounded by sweeping areas of greenery. The building comprises two floors. The first floor houses an information point and reception area for families, wake rooms, the prayer room and café-restaurant. The ground floor is home to the complex management offices.

GARCIA FAURA installed a set of enclosures in aluminium and steel. Enclosures were developed for the interior atriums with iron blind doors and interior dividing walls with partitions fabricated from stainless U-profiles and glazed panels, finished with tempered glass doors. Special mention should be given to a large sliding leaf closure, which stretches almost 19 metres in length. The project was finished off with a display case with an iron sheet metal coffin.

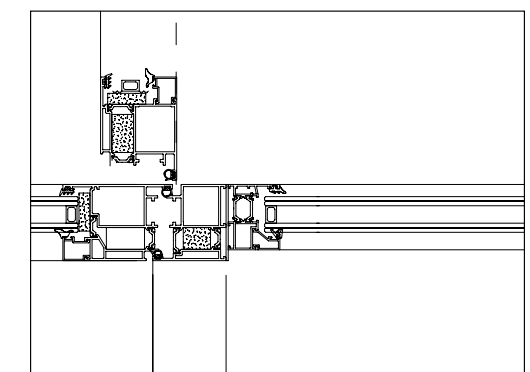
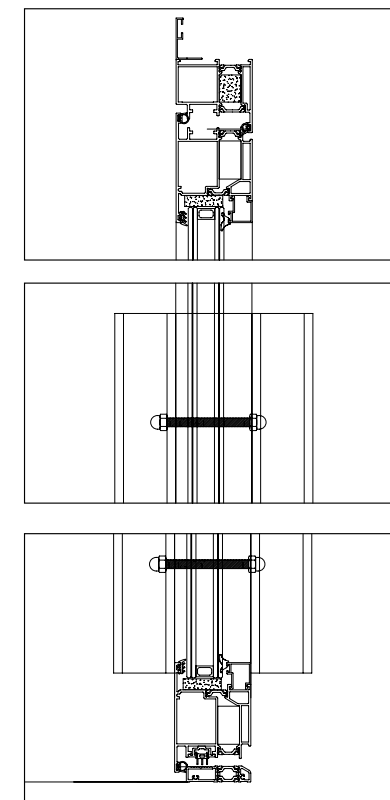



MARTÍ I POUS INSTITUTE

Barcelona (Spain)

GARCIA FAURA
ARCHITECTURE
IN ALUMINUM,
STEEL AND GLASS

MARTÍ I POUS INSTITUTE
Barcelona (Spain)

Year of completion
2018

Architect
Terradas Arquitectos

Works surface area
Enclosures: 179 units

The education centre is located in the Fabra i Coats, a former spinning mill established at the start of the Twentieth Century and decommissioned fully in 2005. The Barcelona City Council acquired the installations in order to convert them into a cultural centre and to house other departments. Works were carried out in accordance with the most characteristic architectural features, with the aim of conserving the historical essence of the Fabra i Coats while allowing it to continue to be a functional building for the education sector.

The main challenge of this project for **GARCIA FAURA** was identifying technical solutions that fulfil project requirements without raising costs. In this sense, for example, the solution implemented to maintain the curved appearance of a section of the building's facade stands out: bending the profiles or manufacturing curved glass panels entailed a high cost, so the placement of a curved sheet metal panel was chosen, which has allowed the exterior appearance of curved shapes to be maintained without the need for the cladding to adopt this shape.

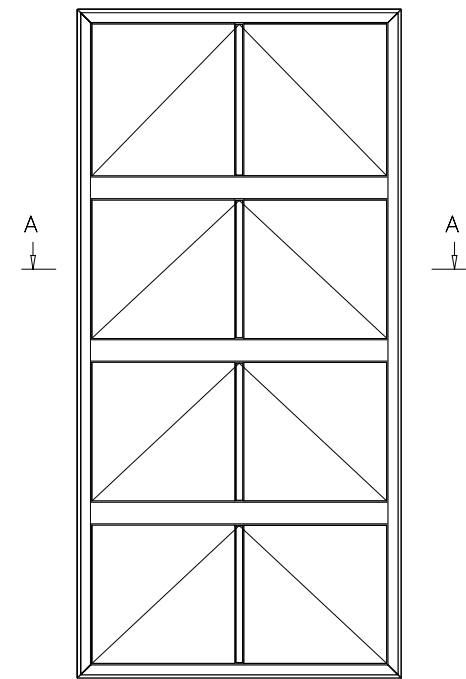

Sección13 A - A

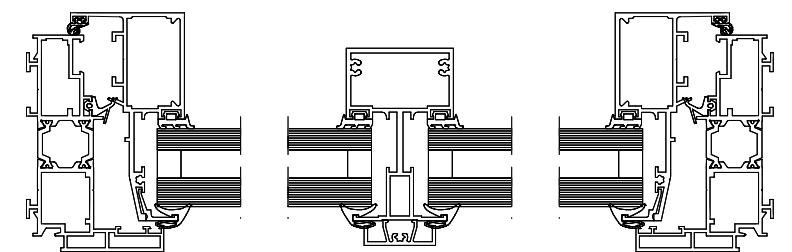

GARCIA FAURA
ARCHITECTURE
IN ALUMINUM,
STEEL AND GLASS



CONDORCET CAMPUS

Paris (France)

GARCIA FAURA
ARCHITECTURE
IN ALUMINUM,
STEEL AND GLASS

CONDORCET CAMPUS
Paris (France)



Year of completion
2019

Architect
Brunet Saunier Architecture

Works surface area
Curtain wall: 1500 m²
Window and door solutions: 2780 m²
Enclosures for ventilation: 400 m²

Also known as the Humanities and Social Sciences Village, it is the largest campus in Europe for research into human and social sciences. The benchmark complex stands in Aubervilliers, in the Ile de France region. A new training, apprenticeship and outreach hub in the humanities field.

GARCIA FAURA installed various double-height enclosures on the ground floor of one of the campus buildings, fabricated entirely from approximately 1500 m² of combined aluminium and steel curtain walling. Aluminium enclosures were also fabricated and installed on the upper floors, developed with an opening French-style aluminium frame and hidden leaf profiles with thermal break, covering approximately 2780 m² in total. Finally, extruded aluminium profile slats were installed, creating enclosures for ventilation covering a total of approximately 400 square metres.

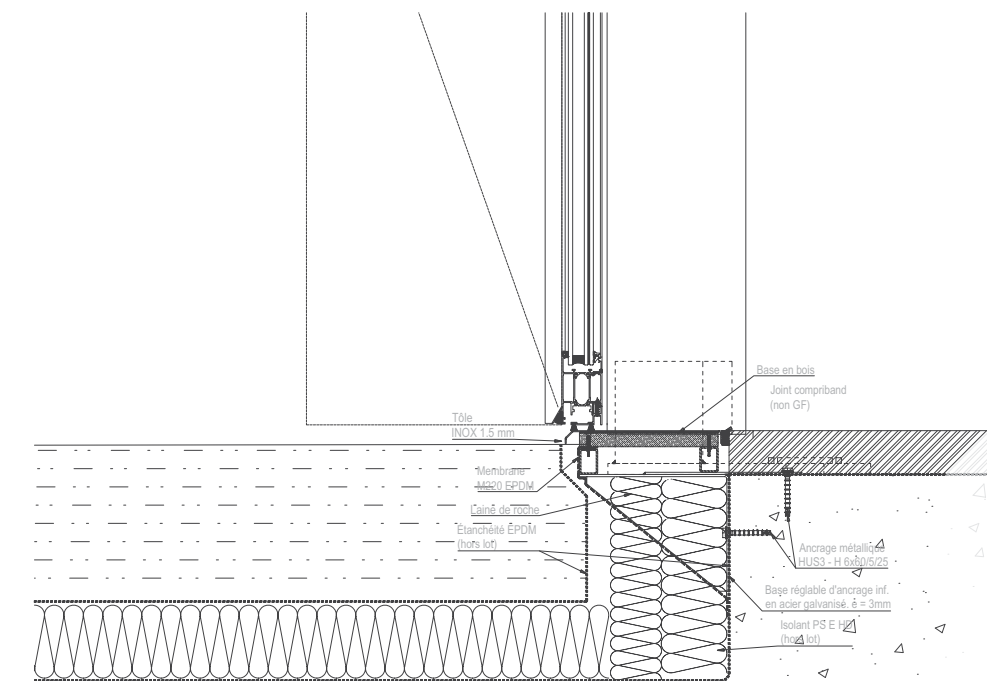

Coupe Verticale A

GARCIA FAURA
ARCHITECTURE
IN ALUMINUM,
STEEL AND GLASS



VILADOMAT HIGH SCHOOL

Barcelona (Spain)

GARCIA FAURA
ARCHITECTURE
IN ALUMINUM,
STEEL AND GLASS

VILADOMAT HIGH SCHOOL
Barcelona (Spain)



Year of completion
2018

Architect
TAC Arquitectes

Works surface area
Enclosures: 950 m²

The secondary education centre occupies part of the jardines de Emma de Barcelona, adjacent to a social housing complex for the elderly and young people, in addition to other public services such as a nursery school. All of these spaces have occupied the island that has been host to a convent since 1841. Its facilities began to be vacated in 1996 with the transfer of the elderly who used to be cared for in the centre that the same community had in Plaza Tetuán.

GARCIA FAURA became involved in the construction of the Institute with 950 square metres of bi-colour enclosures between opening balcony doors, windows and doors in addition to other two and three-track sliding panels. The set of works comprised the prerequisite of meeting the requirements for acoustic and thermal insulation for an education facility and for the comfort of its users. These objectives were met thanks to the technical performance offered by the aluminium systems selected.project.

Secció vertical

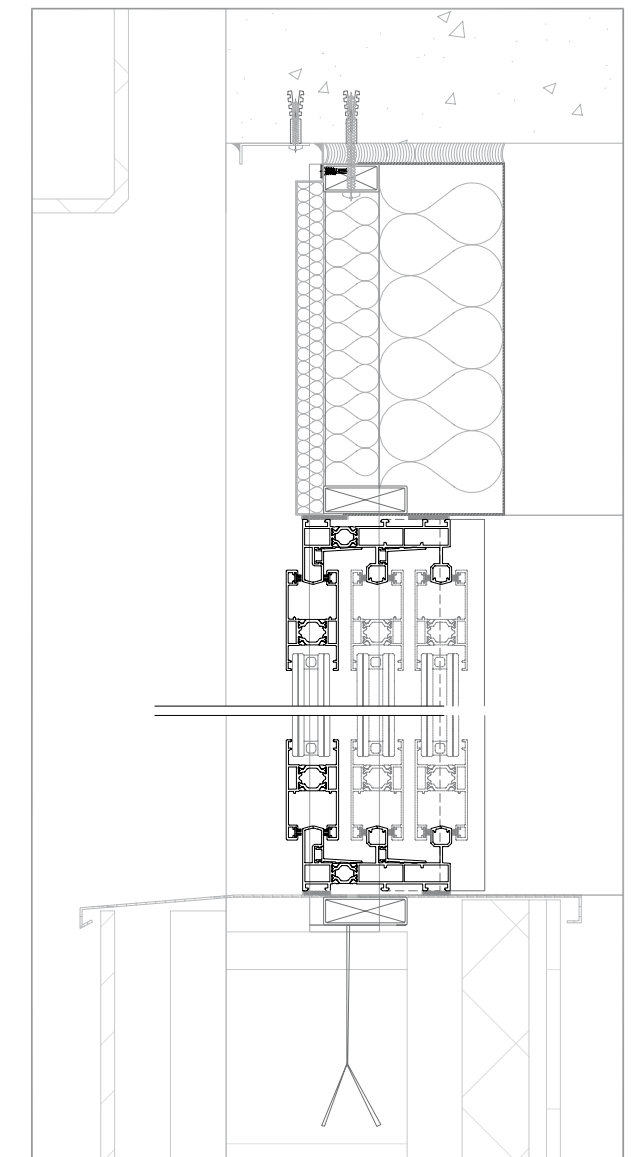

GARCIA FAURA
ARCHITECTURE
IN ALUMINUM,
STEEL AND GLASS

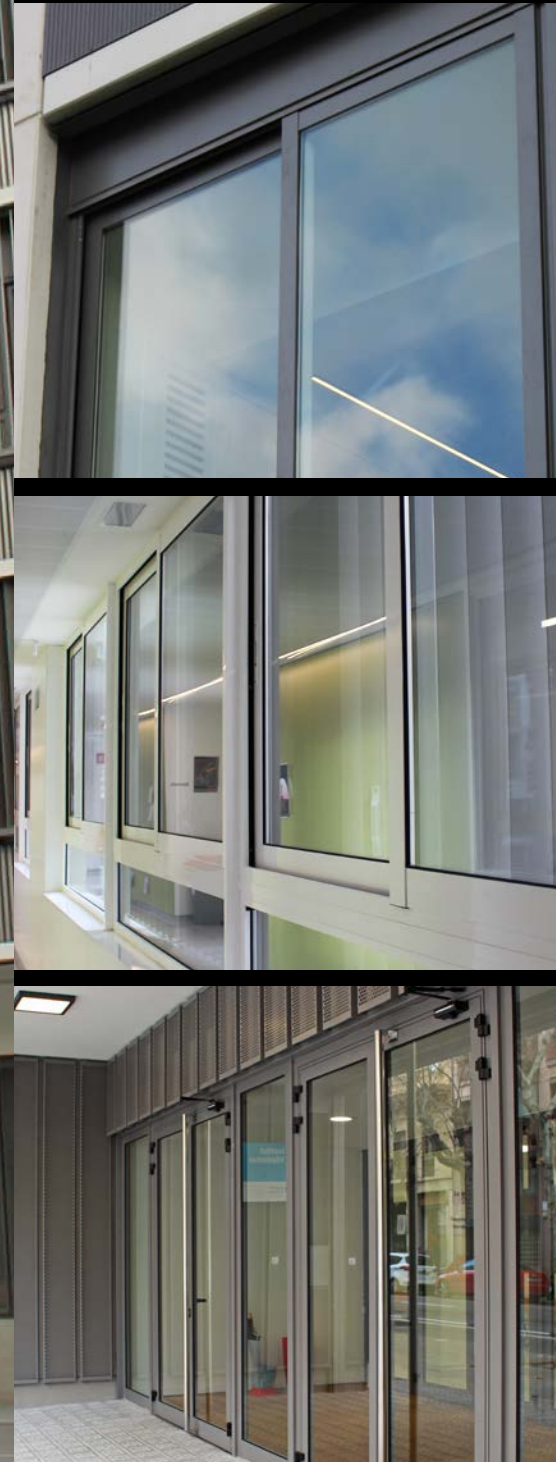



BOEHRINGER INGELHEIM HEADQUARTERS EXPANSION

Sant Cugat del Vallès (Spain)

GARCIA FAURA
ARCHITECTURE
IN ALUMINUM,
STEEL AND GLASS

BOEHRINGER INGELHEIM HEADQUARTERS EXPANSION

Sant Cugat del Vallès (Spain)



Year of completion
2018

Architect
Technip / Ingeprojects

The German pharmaceutical company's Spanish headquarters was extended to create the production facility for an aspirator device for persons with chronic respiratory conditions, that is exported to approximately one hundred countries. The expansion project, which resulted in the creation of 200 jobs, means that the company's site now covers 17,000 square metres separated into production, laboratories, stores, offices and technical departments.



GARCIA FAURA
ARCHITECTURE
IN ALUMINUM,
STEEL AND GLASS

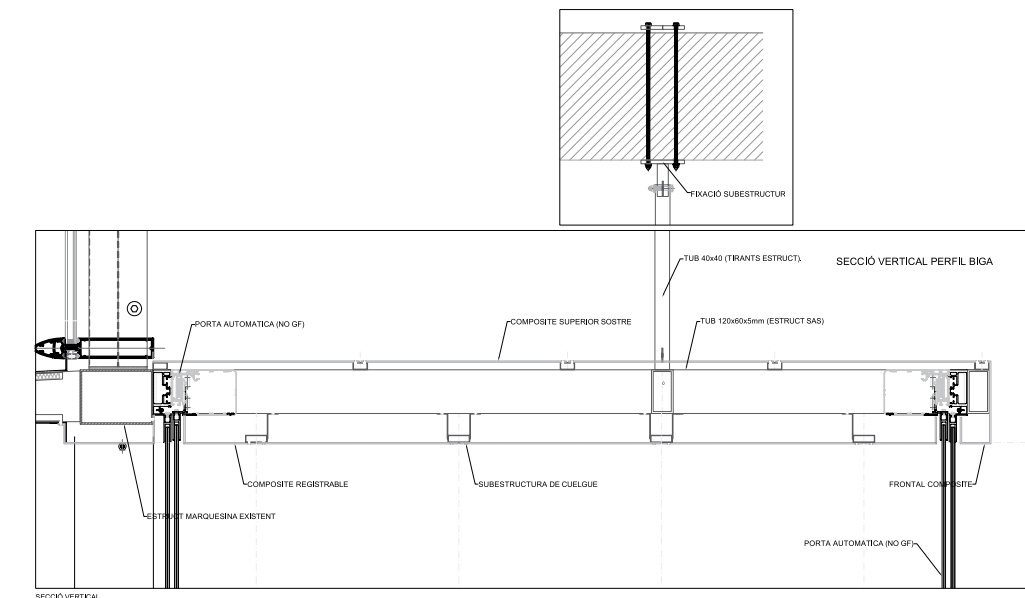



NATURA BISSÉ NEW HEAD OFFICE

Cerdanyola del Vallès (Spain)

GARCIA FAURA
ARCHITECTURE
IN ALUMINUM,
STEEL AND GLASS

NATURA BISSÉ NEW HEAD OFFICE
Cerdanyola del Vallès (Spain)



Year of completion
2019

Architect
Juan Trias de Bes Mingot -
TDB Estudio de Arquitectura 1992

Works surface area
Enclosures: 29 units
Curtain wall: 1087 m²
Skylights: 10 units



The new premises for the cosmetics multinational is located at Parque del Alba, a hotbed for research and production that has emerged around the Synchrotron Park, one of the most important structures in southern Europe. The new head office also comprises innovation, research and training areas. The facilities span five floors with a profile that harmonises with the landscape and which has a visual identity that is in line with the corporate image. The building was constructed on the basis of parameters of sustainability and energy efficiency through the installation of solar energy panels and LED technology in the interiors.

GARCIA FAURA was responsible for the set of 29 large-size enclosures offering high levels of technical and soundproofing performance. Furthermore, **GARCIA FAURA** also installed over 1000 square metres of curtain wall, designed by the company's Technical Department. Of the set of works carried out for this project, the development, fabrication and installation of 10 large skylights and ventilation slats are particularly noteworthy.

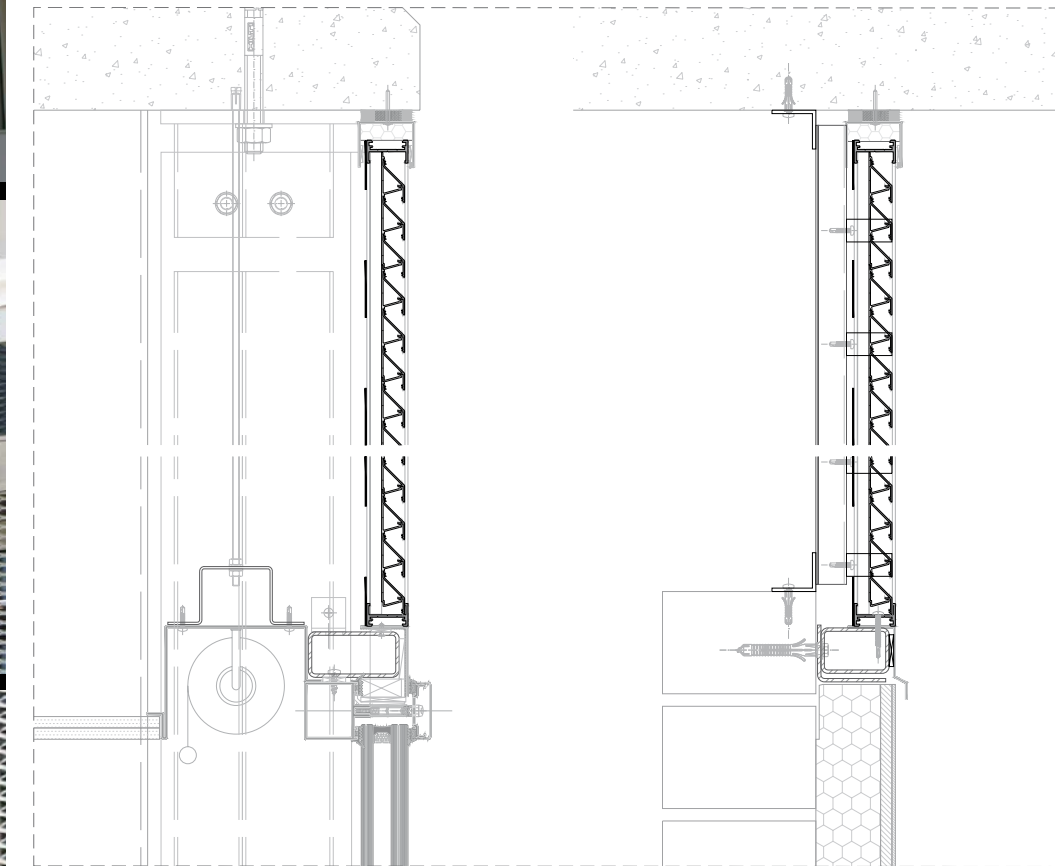

GARCIA FAURA
ARCHITECTURE
IN ALUMINUM,
STEEL AND GLASS



CAN ROCA HIGH SCHOOL

Terrassa (Spain)

GARCIA FAURA
ARCHITECTURE
IN ALUMINUM,
STEEL AND GLASS

CAN ROCA HIGH SCHOOL
Terrassa (Spain)



Year of completion
2018

Architect
Pascual-Ausió Arquitectes SLP

Works surface area
Enclosures: 870 m²

The new Instituto Can Roca building is located between calle Fátima and plaza Rosa Turu. It comprises a ground floor and two floors where the lecture theatre, offices, library, AMPA room, dining room and kitchen are located, not to mention the gymnasium with changing rooms, playground and sports area.

GARCIA FAURA installed 870 square metres of enclosures, including access and interior doors, opening hinged and sliding windows, all with a thermal break. Furthermore, the Institute also combines windows with a high-performance HVAC system that offer excellent sealing results in a way that ensures student safety during their operation. One of the enclosures totals 33 metres in length.

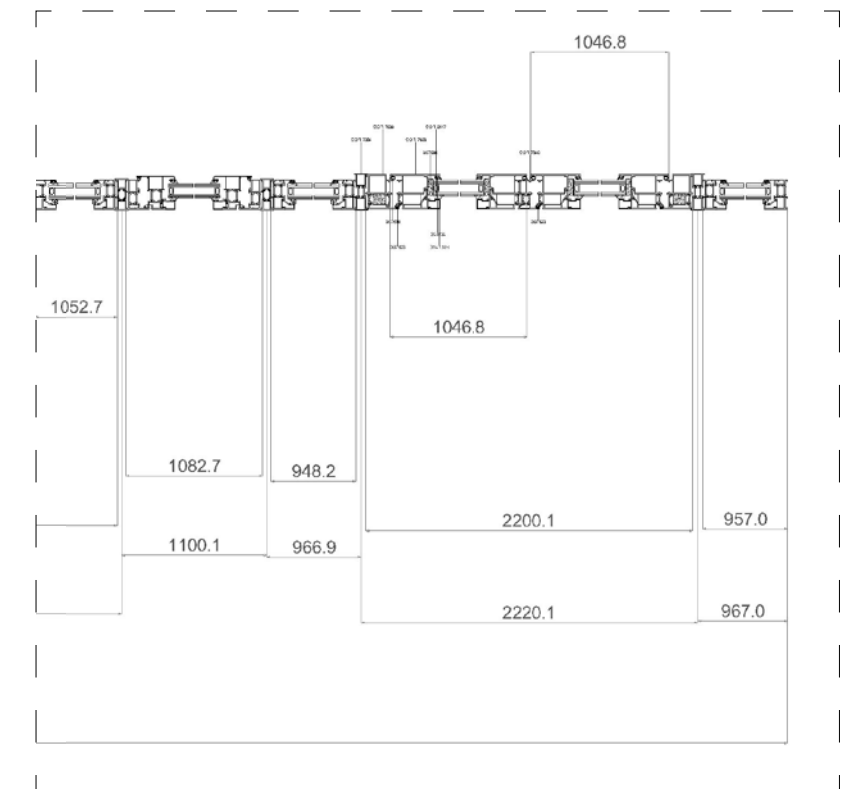

GARCIA FAURA
ARCHITECTURE
IN ALUMINUM,
STEEL AND GLASS



ALTING DIAGONAL REAL ESTATE GROUP HEAD OFFICE

Barcelona (Spain)

GARCIA FAURA
ARCHITECTURE
IN ALUMINUM,
STEEL AND GLASS

ALTING DIAGONAL REAL ESTATE GROUP HEAD OFFICE
Barcelona (Spain)



Year of completion
2019

Architect
JVM ARQUITECTES

Works surface area
Curtain wall: 420 m²
Window and door solutions: 39
stand-alone units
+ 37 units integrated into the facade

Remodelling of the D371 building which has been under the ownership of the real estate group since 2004. Located on the avenida Diagonal, a stone's throw away from the paseo de Gracia, the six-storey building with its triple-glazed glass facade lets in a great deal of light.

The execution of the curtain wall required by **GARCIA FAURA** a great deal of precision, as its polygonal shape required each beam to be unique according to the angles required by the shape of the facade. Works were completed within a very short time frame, requiring the work to be carried out in a highly meticulous way and with total coordination between the Technical Department, Workshop, Installation teams and the project management department.

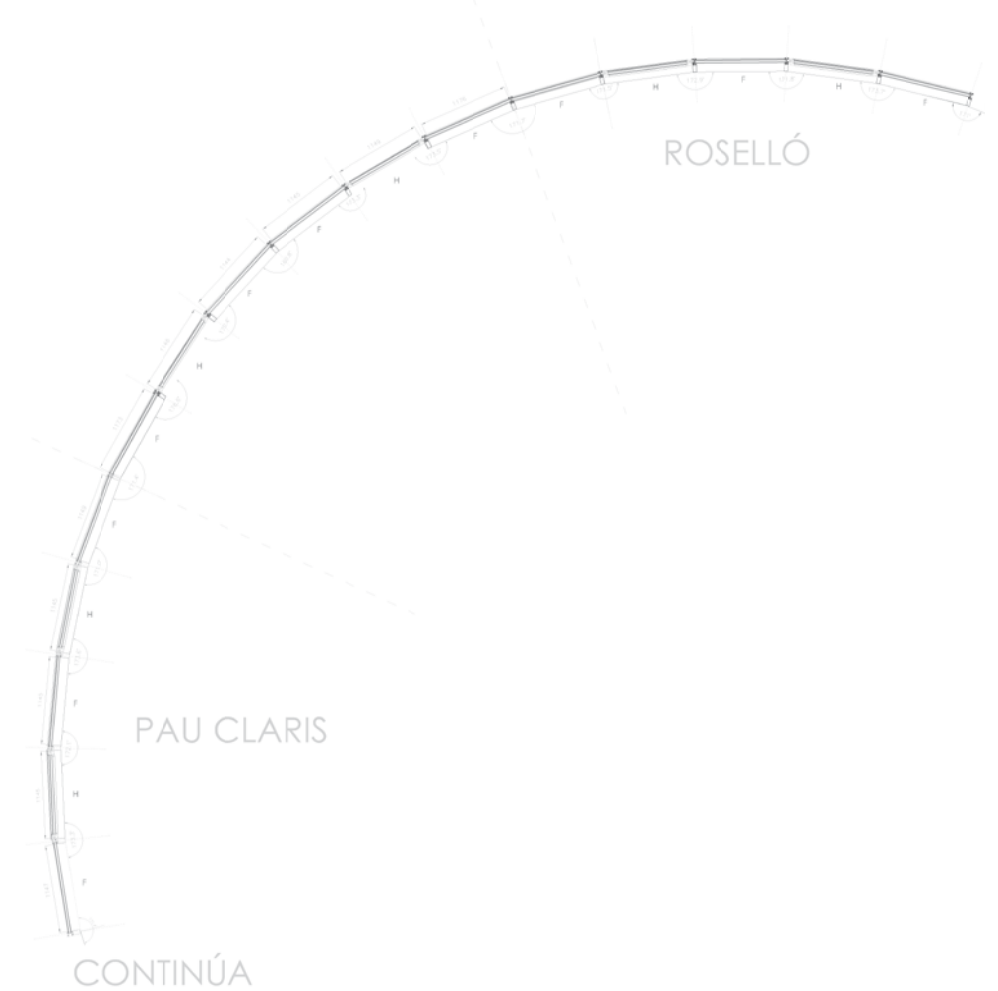

GARCIA FAURA
ARCHITECTURE
IN ALUMINUM,
STEEL AND GLASS



CORFERÍAS HILTON HOTEL

Bogota (Colombia)

GARCIA FAURA
ARCHITECTURE
IN ALUMINUM,
STEEL AND GLASS

CORFERÍAS HILTON HOTEL
Bogota (Colombia)



Year of completion
En construcción

Architect
P&D (Proyectos y Diseños)

Works surface area
Modular facade: 10,500 m²
Curtain wall: 4,000 m²



The new Hilton Bogotá Corferias Hotel will boast 414 rooms and is located in a strategic location: next to the Bogotá Centro Internacional de Negocios y Exposiciones and the Centro Internacional de Convenciones Ágora, developed by the Chamber of Commerce of Bogotá. A new nerve centre of business, business relations and leisure, which is also just 10 minutes from El Dorado International Airport. This fact makes it an excellent benchmark for travellers arriving at El Dorado for their business stay in Corferias.

For this project, **GARCIA FAURA** has been commissioned to join the technical team that will make this new hotel a reality. **GARCIA FAURA** is responsible for the technical development of the external appearance of the building, fabricating and installing 10,500 square metres of modular facade that integrates the set of building enclosures. In addition, **GARCIA FAURA** will also execute 4000 square metres of stick-type facade, both of which form an outer envelope combining great beauty, functionality and luminosity. The works are being carried out according to the schedule of works, with project completion being expected during the second half of 2018.



GARCIA FAURA
ARCHITECTURE
IN ALUMINUM,
STEEL AND GLASS

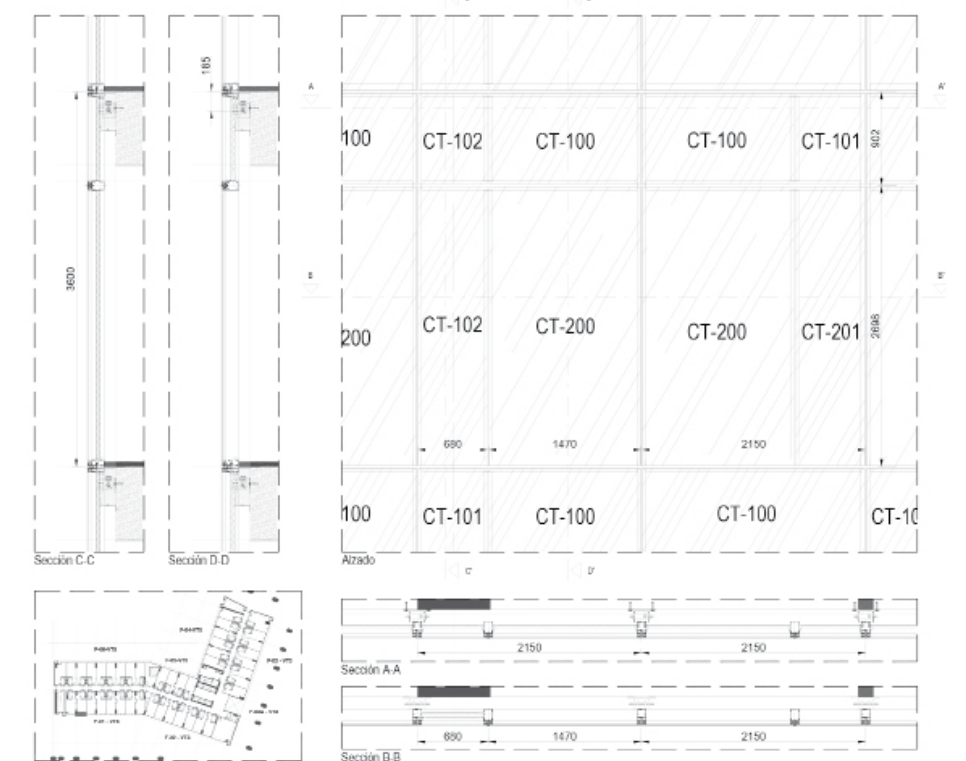



VITRVM TOWER

Bogotá (Colombia)

GARCIA FAURA
ARCHITECTURE
IN ALUMINUM,
STEEL AND GLASS

VITRVM TOWER
Bogotá (Colombia)



Year of completion
Under construction

Architect
Richard Meier

Works surface area
Glass facade: 6.890 m²

Enclosures: 356 u.

Composite cladding: 4.930 m²



GARCIA FAURA
ARCHITECTURE
IN ALUMINUM,
STEEL AND GLASS

Torre Vitrum is the first project in Colombia designed by Richard Meier & Partners. This project is contextually inspired by the beauty of its close environment, and its aim is to reflect, respect and participate in the nature that converges in the place. The building is characterized by its singular shape, prismatic and clearly articulated by folds, planes, and cut surfaces, related with its immediate environment, the orientation of the building to the views of the city and the privacy of each unit. Torre Vitrum is located in a prominent place in one of the most important avenues of the north section of Bogotá. It consists in 2 bodies 13 and 11 stores high that will host apartments with surfaces between 267 and 395 square metres.

GARCIA FAURA develops in this singular project two different types of light façades: 7000 square metres of glass and 5000 square metres of aluminium panels. The glass, manufactured particularly for this project, are composed of an external extra-clear glass, a solar control coating, and an internal glass with a low-emissive coating. This combination allows a great reduction in the thermal transmittance and a great control of the solar factor, creating a great sensation of comfort in the interior keeping the maximum visual transparency required by the architectural project. The structure of the façade is performed with high performance profiles of the highest quality. These works are combined with other zones glazing with silk-screen painting an opaque glass. The project contemplates various types of openings as well, all with aluminium profiles with hidden slash.

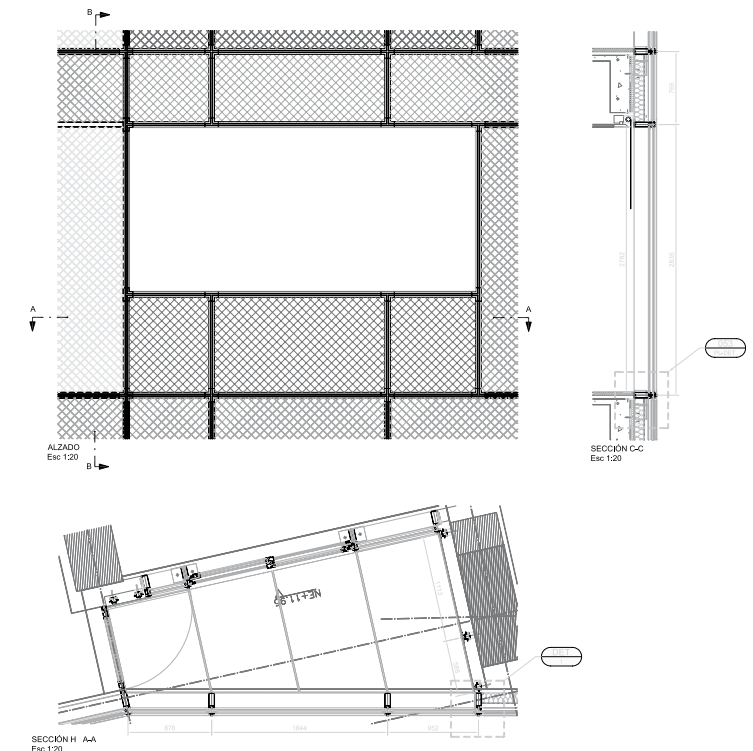



RENOVATION OF THE BEETHOVEN BUILDING

Barcelona (Spain)

GARCIA FAURA
ARCHITECTURE
IN ALUMINUM,
STEEL AND GLASS

RENOVATION OF THE BEETHOVEN BUILDING

Barcelona (Spain)



Year of completion
2017

Works surface area
Curtain wall: 2178 m²
Windows: 203 u.

Located in the uptown area of Barcelona, in a location favoured by an extensive business sector, the Beethoven building covers a surface area of almost 7000 square metres intended for commercial properties and offices. The building has a functional and practical design, aiming to ensure the efficiency and cost-effectiveness of the space without impacting comfort.

GARCIA FAURA has installed a new curtain wall in front of the existing one. This comprises 2178 square metres covered by 203 windows with weathering steel finishing and interior opening panes inserted into the curtain wall. For this project, the Drawing office has worked with a particularly innovative system, enabling the new facade to be installed over the one already in place. Once the works were completed, the previous facade was deconstructed from inside. Therefore, the building was not left unclad during the process, and as a result, any impact on its day-to-day operations was minor.

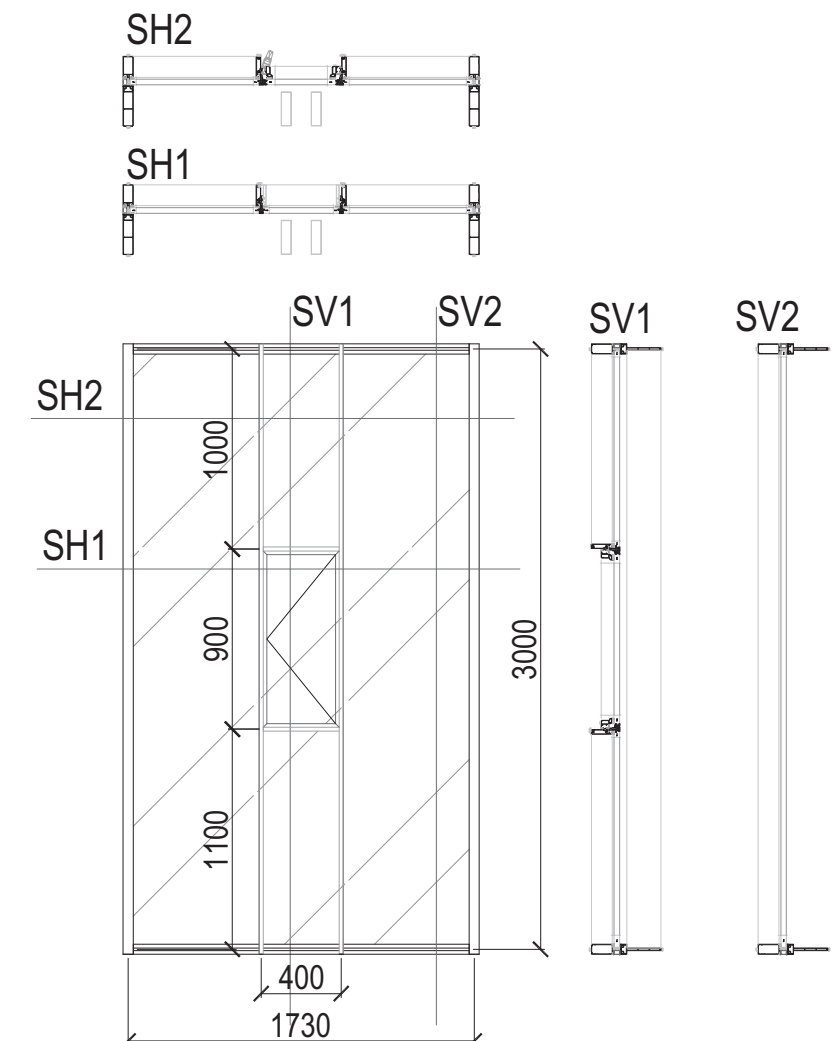

GARCIA FAURA
ARCHITECTURE
IN ALUMINUM,
STEEL AND GLASS



PALAIS DE JUSTICE

Paris (France)

GARCIA FAURA
ARCHITECTURE
IN ALUMINUM,
STEEL AND GLASS

PALAIS DE JUSTICE, PARIS
Paris (France)



Year of completion
2018

Architect
Renzo Piano Building Workshop

Works surface area
Cell enclosures: 220 u.
Exterior glazed facade: 2800 m²
Doors: 180 u.

GARCIA FAURA constructed for this project a set of enclosures for interior cells, using door systems and solutions designed especially for the project, such as serving hatches or ventilation openings. Furthermore, almost 3000 square metres of curtain walling and interior doors have been fabricated and installed.

The main resulting challenge has been the integration of the fabrication and installation processes into the specific logistics of the project, one of the largest-volume constructions created recently in Europe, including up to 1000 operatives working each day on each of the construction processes of the project.

Throughout the process, the **GARCIA FAURA** Drawing office has undertaken various detailed studies of the fabricated components in order to meet the fire break and soundproofing requirements presented by the project. The stringent safety requirements have meant working with thick glazing panels which have made installation work more challenging due to their significant weight. All works have been completed satisfactorily, contributing to the overall success of the project.

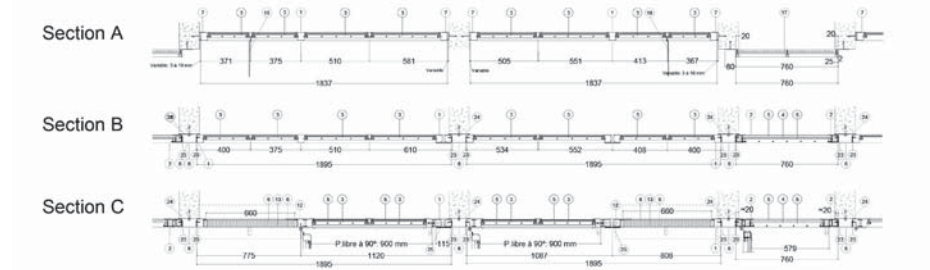
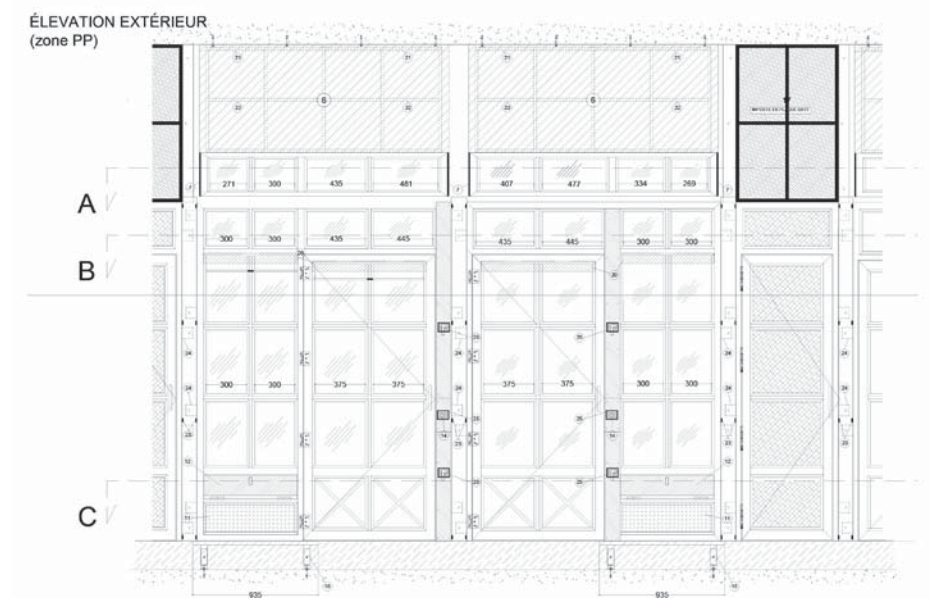

GARCIA FAURA
ARCHITECTURE
IN ALUMINUM,
STEEL AND GLASS



LISBON OCEANARIUM EXTENSION

Lisbon (Portugal)

GARCIA FAURA
ARCHITECTURE
IN ALUMINUM,
STEEL AND GLASS

LISBON OCEANARIUM EXTENSION
Lisbon (Portugal)

The Lisbon Oceanarium, the second largest aquarium in Europe, was inaugurated in 1998 as part of the World Fair Expo. It was designed by architect Peter Chermayeff as a floating port, accessible via two gangways. The facility is located in the Parque de las Naciones district, which is one of the most futuristic areas of the Portuguese capital city. Inside and spread over two floors, up to 15,000 living examples of more than 450 different species can be found, whose natural habitats are the Atlantic, Indian, Pacific and Southern Oceans.

GARCIA FAURA was contracted to construct a U-shape facade enclosure and to install a fastened glass facade comprising a total of 882 square metres. The **GARCIA FAURA** Drawing Office and Design and Calculation department have worked extensively on an optimised solution for the project, based on the steel or concrete columns already in situ. In addition, **GARCIA FAURA** has installed sixty square metres of enclosures with ventilation slats in the upper section of the building wall. The company has also installed four automatic doors and a mobile platform for cleaning the building exterior.



GARCIA FAURA
ARCHITECTURE
IN ALUMINUM,
STEEL AND GLASS

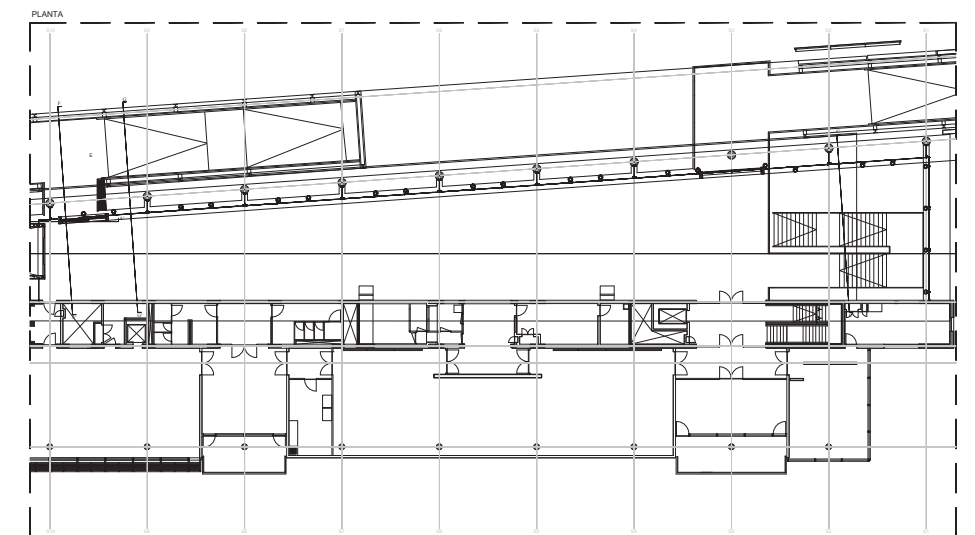



SANCHO DE ÁVILA FUNERAL PARLOUR

Barcelona (Spain)

GARCIA FAURA
ARCHITECTURE
IN ALUMINUM,
STEEL AND GLASS

SANCHO DE ÁVILA FUNERAL PARLOUR
Barcelona (Spain)



Year of completion
2018

Architect
JF Arquitectes

Works surface area
Curtain wall: 315 m²
Window and door solutions:
450 m²
Glass skylights, bannisters and
screens

The new Sancho de Ávila funeral parlour in Barcelona is constructed on the same plot as the previous facilities, covering an area of 10,000 square metres and 1400 square metres of garden. It has two central buildings, one for services and another that houses the oratories and about thirty viewing rooms. Both are connected by a large garden square that will fulfil the function of distributing traffic. Natural light is given great importance, with an opaque facade towards the exterior and open towards the central square. The block of offices and services also has a large curtain wall and a second metallic skin, also favouring maximum light ingress not to the detriment of privacy.

GARCIA FAURA created the glazed facades, entrances and aluminium enclosures. 315 square meters of curtain wall with perimeter profiles and high-performance technical glass have been developed, as well as a set of exterior works consisting in fabricating and installing skylights, glass screens, fixed areas and bannisters. The set of aluminium doors and windows has been installed in the section of enclosures, covering approximately 450 square meters, as well as all entrances and exits, with revolving, tilting and firebreak doors. All this contributes to cover the use requirements for the different areas, but also to convey the aesthetic appearance of the highly individual project.



GARCIA FAURA
ARCHITECTURE
IN ALUMINUM,
STEEL AND GLASS

DETALL C

DETALL D

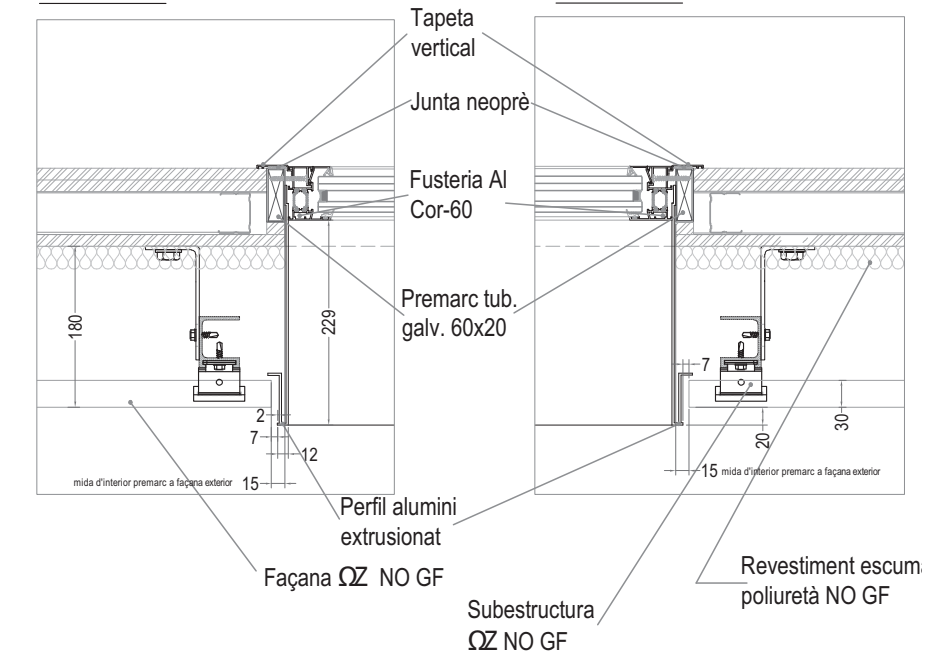



ME SITGES TERRAMAR HOTEL

Sitges (Spain)

GARCIA FAURA
ARCHITECTURE
IN ALUMINUM,
STEEL AND GLASS

ME SITGES TERRAMAR HOTEL
Sitges (Spain)



Year of completion
2017

Architect
Daniel Isern

Works surface area
Enclosures: 292 units
Glass: 2087 m²

The Meliá Hotels Group manages the new Hotel Terramar de Sitges, a classic from the hotel facilities network on the Garraf coast, which has undergone a thorough renovation with the aim of integrating into the range of resorts from the ME by Meliá brand, which brings together high-level and leading-edge facilities. The new Terramar comprises 213 rooms and two restaurants, as well as spaces for shared use available to guests, such as wellness rooms, events areas, children's clubs, etc.

GARCIA FAURA has contributed to this significant renovation project by providing leading manufacturer high-performance aluminium enclosures, in accordance with the general quality and aesthetic requirements synonymous with the new hotel. In this sense, 2087 square metres of glass and 292 enclosures have been fabricated and installed, comprising aluminium systems with high-tech thermal bridge breakage. The enclosures are, in addition, specially designed to withstand the inclement weather and environmental conditions of a building located on the seafont.

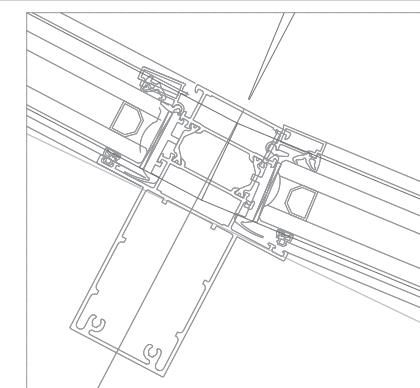
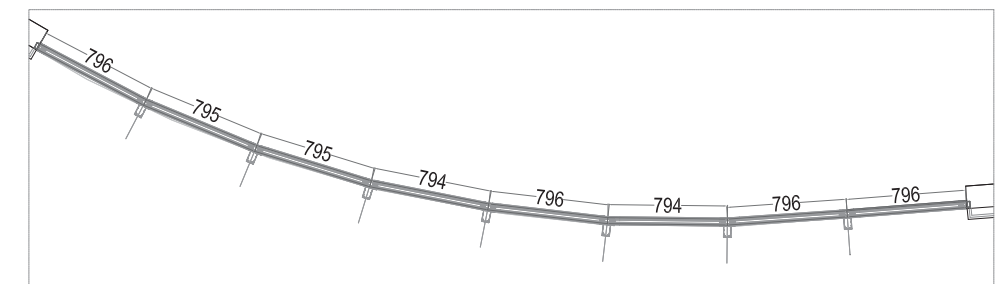
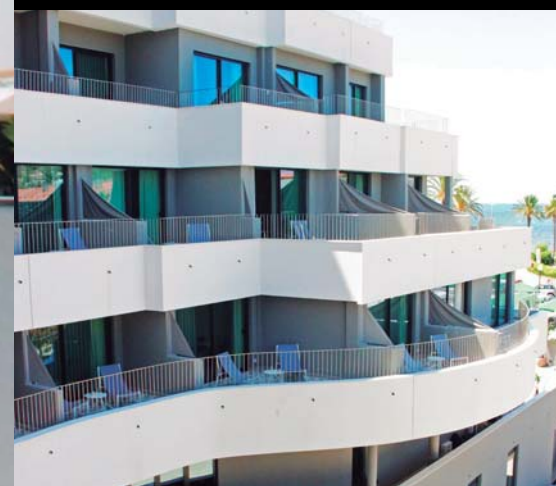

GARCIA FAURA
ARCHITECTURE
IN ALUMINUM,
STEEL AND GLASS



IBEROSTAR PASEO DE GRACIA HOTEL

Barcelona (Spain)

GARCIA FAURA
ARCHITECTURE
IN ALUMINUM,
STEEL AND GLASS

IBEROSTAR PASEO DE GRACIA HOTEL
Barcelona (Spain)

Year of completion
2017

Architect
Félix Linares

Works surface area
Steel enclosures: 210 units

One of the most symbolic buildings in the Plaça de Catalunya in Barcelona is once again occupied after years of disuse. We are talking about the former Banesto building, on the corner with Paseo de Gracia. The building owner took the decision to rent it to the Iberostar hotel chain, for them to convert the building into a four-star hotel with the intention of establishing itself as a tourist landmark in the Catalan capital; not only because of its strategic location, but also because of the services it offers.

GARCIA FAURA has emerged clearly in recent years as a benchmark company in the hotel sector, both for new construction and renovation. In this specific case, the company has been commissioned to develop, fabricate and install the set of exterior enclosures for the new establishment; more than 200 units together. To retain the stately aesthetics of the building, and not lose the characteristics specific to the facade, the enclosures have been made from steel, ensuring first class visual and technical features. All of this is to the benefit of the levels of comfort desired for the guests, yet retains the visual individuality of a historic building like this.

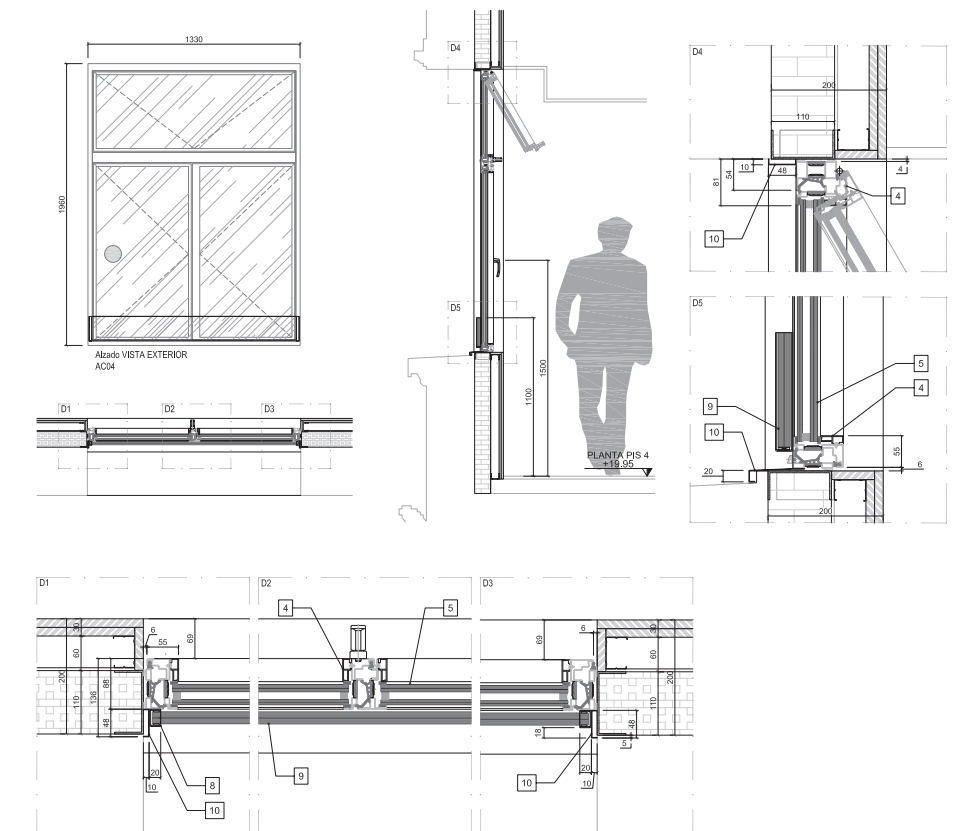

GARCIA FAURA
ARCHITECTURE
IN ALUMINUM,
STEEL AND GLASS



AMAZON LOGISTICS CENTER

El Prat de Llobregat (Spain)

GARCIA FAURA
ARCHITECTURE
IN ALUMINUM,
STEEL AND GLASS

AMAZON LOGISTICS CENTER
El Prat de Llobregat (Spain)

Year of completion
2017

Architect
Idom

Works surface area
Motorised windows: 156 units
Turn-tilt windows: 252 units
Fixed windows: 756 units

The online business giant has invested 200 million euros in a new logistics center, the second of its type in Spain. It is located strategically close to Barcelona airport and port. With a total storage capacity of 210,000 m² covering multiple floors, and built on a plot covering 150,000 m², it is the largest and most modern logistics center in southern Europe.

GARCIA FAURA produced the set of enclosures for this vast logistics facility. A total of almost 1200 windows; most fixed and turn-tilt, but some motorised also. The main challenge of this project was to meet the works scheduling requirements, which set very demanding works installation targets. The company invested all of its productive and assembly capabilities into this works schedule, managing to meet the deadlines without impacting quality or technical performance.

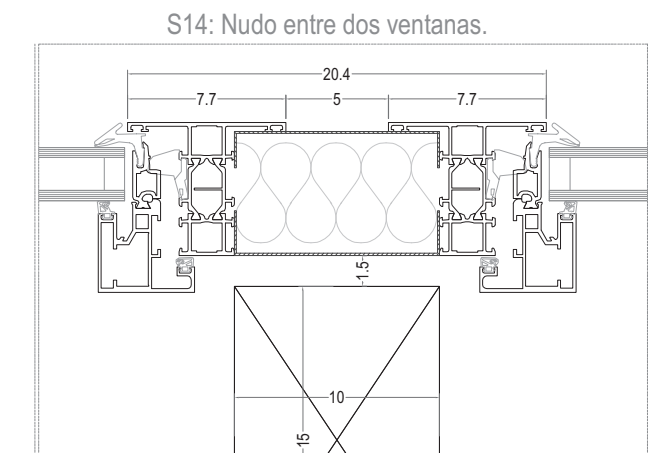
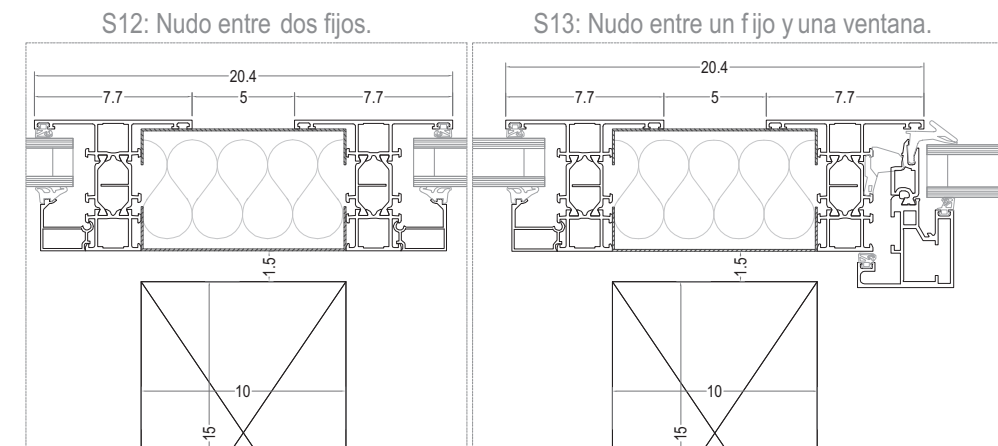

GARCIA FAURA
ARCHITECTURE
IN ALUMINUM,
STEEL AND GLASS



LLARS DE L'AMISTAT RESIDENTIAL CENTER

Mataró (Spain)

GARCIA FAURA
ARCHITECTURE
IN ALUMINUM,
STEEL AND GLASS

LLARS DE L'AMISTAT RESIDENTIAL CENTER
Mataró (Spain)



Year of completion
2017

Works surface area
Enclosures: 94 units
Glass: 274 m²

New residential center for people with significant physical disabilities, managed by the Fundació Llars de l'Amistat Cheshire in Mataró. This is a building that increases from the 23 seats that were in the previous building to a maximum capacity of 36. The building, located in the centre of Mataró, has been adapted comprehensively to the requirements of disabled users. Apart from the rooms for residents, it also has expansive communal areas, such as the attic, where activities of all kinds are carried out.

For this project, **GARCIA FAURA** has fabricated and installed around one hundred aluminium enclosures with thermal bridge breakage, most of them with concealed sheets. A more aesthetic and cutting-edge solution that allows a more efficient use of natural light, reducing the thickness of exposed aluminium profiles to a bare minimum. The enclosures are dual-coloured, allowing the exterior aesthetics of the building to shine through but offering greater colour neutrality inside. Works were completed with a set of fixed glass partitions and enclosures.



GARCIA FAURA
ARCHITECTURE
IN ALUMINUM,
STEEL AND GLASS



CENTRO CULTURAL PLAÇA NOVA

Sant Sadurní d'Anoia (Spain)

GARCIA FAURA
ARCHITECTURE
IN ALUMINUM,
STEEL AND GLASS

CENTRO CULTURAL PLAÇA NOVA
Sant Sadurní d'Anoia (Spain)



Year of completion
2017

Architect
Taller 9S arquitectes

Works surface area
External enclosures: 250 m²
Curtain wall: 200 m²
Glass screens and doors: 200 m²
Skylight: 8m²

New Sant Sadurní d'Anoia cultural facility inaugurated at the end of 2017, and located in the remodelled former School building in Plaza Nueva. Currently, the Ramon Bosch de Noya Municipal Library is located here, but a second phase will locate the Municipal Archive here also. The building comprises various furnished multi-function rooms and areas equipped with sound and security systems, available for private individuals, groups and companies.

GARCIA FAURA has participated in the construction process of this new facility, having been commissioned to manufacture and install the exterior enclosures, a skylight, a small curtain wall and the set of glass screens and interior doors. The set of exterior enclosures, totalling 250 square metres, has been developed with concealed sheet aluminium profiles, which minimises the impact of the profile volume and gains maximum interior brightness. Furthermore, the glass panes also have a low-emissivity coating, which provides the facility with greater comfort. The same is applicable to the skylight and the curtain wall, which total about 210 square metres and integrate with the overall aesthetics of the architectural project.

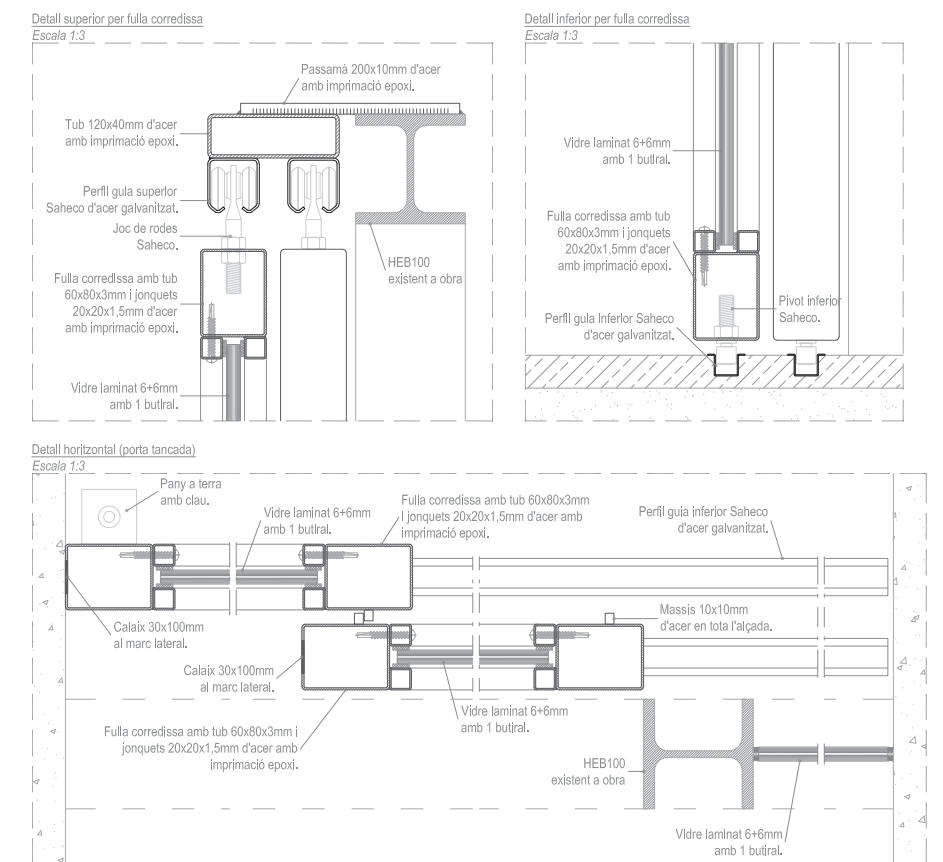
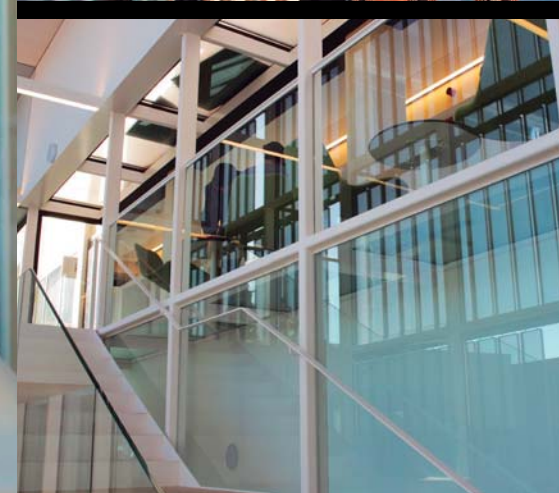

GARCIA FAURA
ARCHITECTURE
IN ALUMINUM,
STEEL AND GLASS



NEW BETÀNIA PATMOS SCHOOL BUILDING

Barcelona (Spain)

GARCIA FAURA
ARCHITECTURE
IN ALUMINUM,
STEEL AND GLASS

NEW BETÀNIA PATMOS SCHOOL BUILDING

Barcelona (Spain)

Year of completion

2017

Architect

Capilla-Mónaco Arquitectos

Works surface area

External enclosures: 800 m²

Skylights: 117 m²

Motorised mobile solar panel facade: 480 m²

The extension of Betania Patmos School, in Barcelona, aims to create a new teaching space based on a building of great character, that is fully integrated into the landscape and topography of the land, that is therefore, highly sustainable. The creation of landscaped roofs and the installation of solar panels contribute to this approach elements such as the orientation of the building, which prioritises the most effective use of natural light. User convenience has been another line of focus taken into account by the project, with all classrooms exiting directly into the courtyard and through the provision of ramps for indoor connections.

GARCIA FAURA has developed the set of skylights and solar panel facades, both mobile and motorised and incorporating a triangular design, that combine functionality and aesthetic impact. The works also include the fabrication and installation of 800 square metres of exterior enclosures comprising high-performance aluminium profiles, both opening and sliding. Enclosures integrating double glazed panes developed with low emissivity and acoustic control further increase the performance of the enclosures and develop the project aim of providing facility comfort and a high level of thermal and acoustic insulation to facilitate teaching and learning activities.

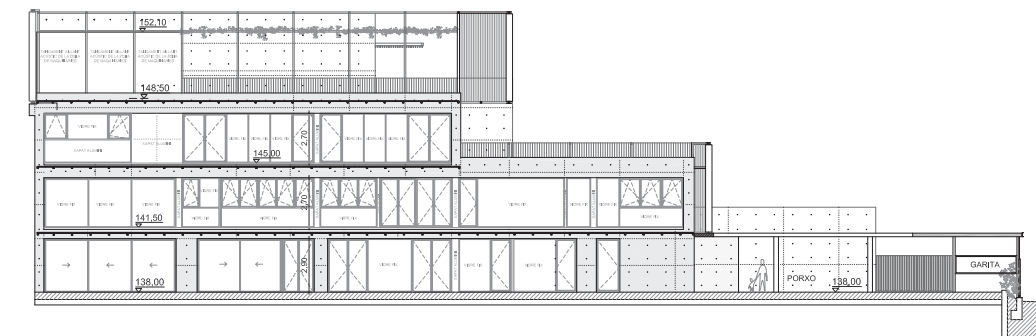
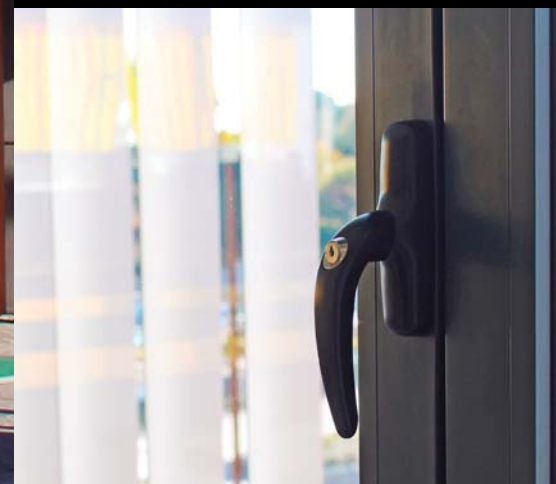
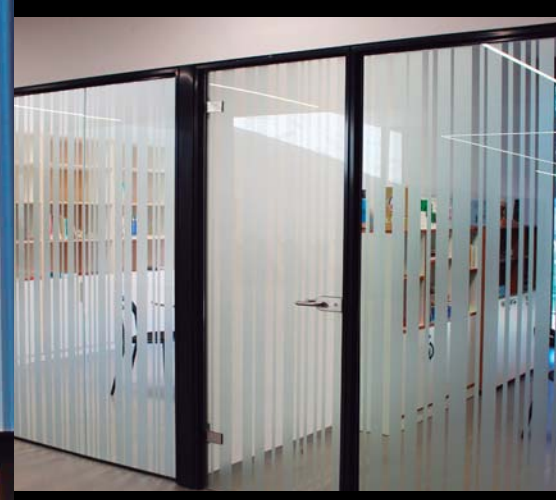

ALÇAT SENSE LAMEL·LES

GARCIA FAURA
ARCHITECTURE
IN ALUMINUM,
STEEL AND GLASS



CORNELLÀ RESIDENTIAL CENTER

Cornellà de Llobregat (Spain)

GARCIA FAURA
ARCHITECTURE
IN ALUMINUM,
STEEL AND GLASS

CORNELLÀ RESIDENTIAL CENTER
Cornellà de Llobregat (Spain)



Year of completion
2016

Works surface area
Enclosures: 189 units
Automatic doors: 2 units

The focus of this installation architectural project was to create a new building with dual functionality: the main one, the creation of a residential center for the elderly; at the same time, the equipment needed to coexist with a freely accessible commercial surface. Both requirements have been fulfilled with a compact and functional building, which allows people to circulate inside without architectural barriers and with a high level of technical functionality that permit continuous daily use in both spaces.

For this project, **GARCIA FAURA** has progressed the fabrication and installation works for the facility metal structure assembly. Specifically, 189 aluminium and glass doors, windows and balconies, especially designed to offer maximum comfort to the users of the residential center, fulfilling the acoustic and thermal insulation needs of an installation with these specifications. Furthermore, two automatic doors have been installed in the facility entrances.



GARCIA FAURA
ARCHITECTURE
IN ALUMINUM,
STEEL AND GLASS



CAP SANT PERE DE RIBES

Sant Pere de Ribes (Spain)

GARCIA FAURA
ARCHITECTURE
IN ALUMINUM,
STEEL AND GLASS

CAP SANT PERE DE RIBES
Sant Pere de Ribes (Spain)

Year of completion
2017

Architect
Albert Vitaller i Laia Isern

Works surface area
Enclosures: 39 units
Curtain wall: 440 m²

The new health center in the city of Garraf is located on the Paseo de la Circunvalación and is designed to serve a population of up to 30,000 users. The 1780 square-metre project comprises a low-rise building that adapts to the specific topography of the land and forms a link between the urban space and the natural environment. The services are distributed across two bodies connected by a central square, used as a channel for distribution and connection with the environment.

GARCIA FAURA has been commissioned to execute the construction work relating to the new facility's aluminium enclosures, as well as the curtain wall area that bestows a character of its own on the exterior façade and greater use of external light. In addition, the enclosures have been projected with thermal bridge breakage and concealed sheets, to provide facility users with optimised conditions of comfort.

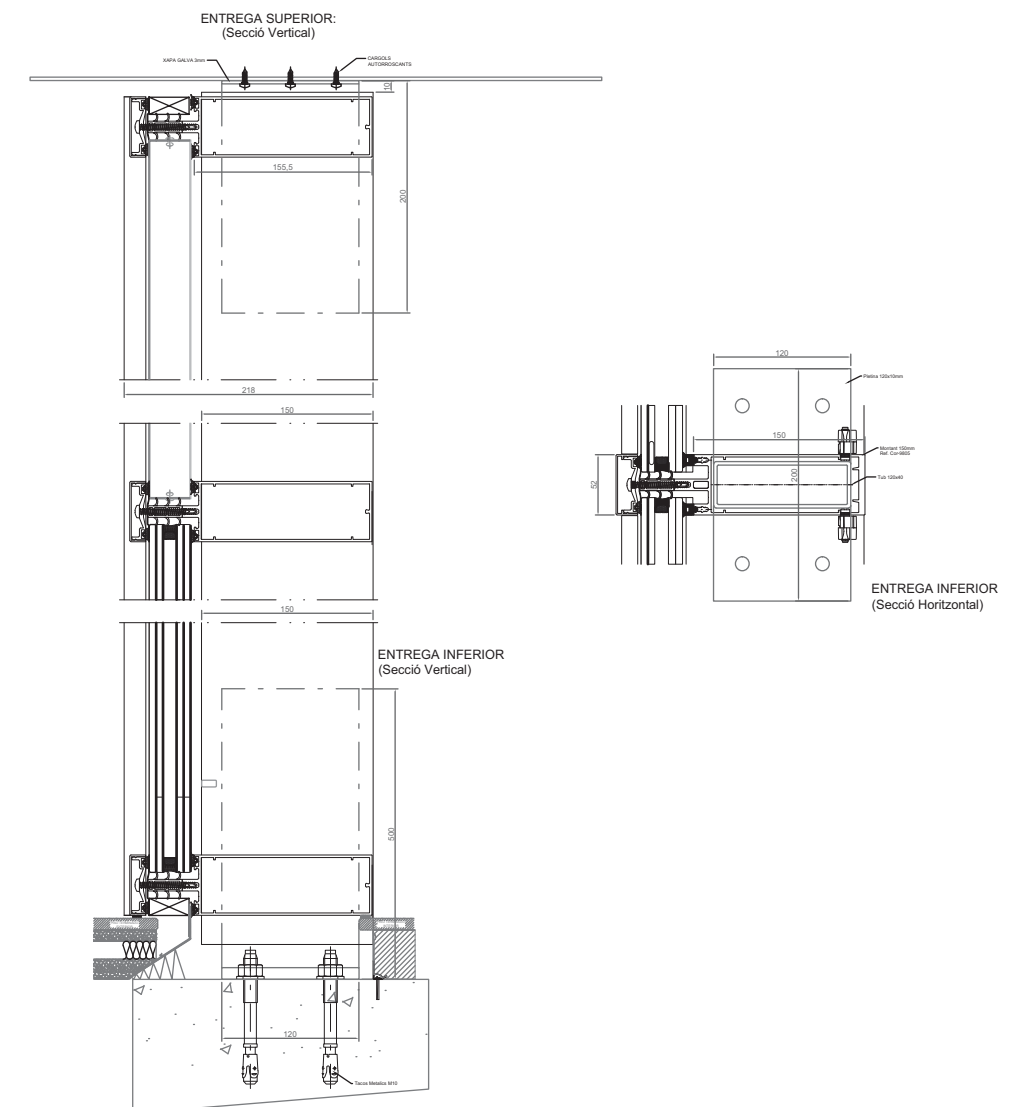

GARCIA FAURA
ARCHITECTURE
IN ALUMINUM,
STEEL AND GLASS



MONTGAT MUNICIPAL MARKET

Montgat (Spain)

GARCIA FAURA
ARCHITECTURE
IN ALUMINUM,
STEEL AND GLASS

MONTGAT MUNICIPAL MARKET
Montgat (Spain)



Year of completion
2017

Architect
GRAM arquitectura i urbanisme

Works surface area
Enclosures: 12 units
Facade cladding: 50 m²

The Montgat Market comprises more than 4000 m² for the provision of goods and services. There are 17 businesses from diverse sectors and a Mercadona supermarket. All together, they form part of a comprehensive offering for foodstuffs, catering and services, making it a benchmark for shopping in the Baix Maresme area, in addition to being a well-connected facility with free parking, where you can enjoy green spaces, children's areas and restaurant terraces.

The work carried out by **GARCIA FAURA** in this new commercial center consisted in fabricating and installing around a dozen large-scale glass and aluminium enclosures with thermal breakage, for the global enclosure of the ground floor. Works included the UPN-type profile substructures. Works relating to the recladding of the facade have also been completed, using aluminium veneers.



GARCIA FAURA
ARCHITECTURE
IN ALUMINUM,
STEEL AND GLASS



PAU CASALS SCHOOL RENOVATION

Rubí (Spain)

GARCIA FAURA
ARCHITECTURE
IN ALUMINUM,
STEEL AND GLASS

PAU CASALS SCHOOL RENOVATION
Rubí (Spain)

Year of completion
2016

Works surface area
Enclosures: 88 units

The remodelling works of the Pau Casals School were initiated with an initial phase of remodelling of the building's concierge section, toilets, walkways and interior joinery and the improvement of the electrical and heating installation, amongst other things. The second phase will entail improvements to the facade and installation of a lift. The works were designed with the aim of avoiding disruption to pupils and teachers as far as possible.

GARCIA FAURA took part in the second phase of this work to install the windows in the south and north facades. It was decided to manufacture windows with thermal bridge breakage that stand out for their superior insulation that guarantees the comfort of center users. The company has a long history both in renovation and in new builds destined for educational applications, being especially efficient when these works are usually carried out during school holidays.



GARCIA FAURA
ARCHITECTURE
IN ALUMINUM,
STEEL AND GLASS



UB LAW FACULTY EXTENSION

Barcelona (Spain)

GARCIA FAURA
ARCHITECTURE
IN ALUMINUM,
STEEL AND GLASS

UB LAW FACULTY EXTENSION
Barcelona (Spain)

Year of completion
2017

Architect
Jordi Marcè

Works surface area
Glass façade: 7.500 m²
Composite: 410 m²
Enclosures: 250 units

The University of Barcelona enlarges its Law School. The new facilities are 4 stores high with a basement, and host around twenty work rooms, a mediation room and a room to simulate judgements, among others. The university pretends to give an answer to the need teaching needs y continue advancing in the improvement of the quality of its academic activity. Besides, the new building allows to transfer the studies of Labour Relations, currently taught at the Diagonal Sur Campus. All of this in a new construction building that follows the orthogonality of the historical building, which stands on one of the sides of the parcel, perpendicularly to Diagonal avenue.

GARCIA FAURA executes for this project the totality of the curtain wall, over 7500 square metres. The curtain wall is composed by double mullions and transoms, covered with glass with perimetric opaque silkscreen painting, and with composite in the spandrel zones. The 4 buildings are communicated with each other through gateways with mixed metallic and concrete slabs, for which a special type of anchors has been designed. The curtain wall contemplates windows and doors with 1 or 2 opening sheets.

The closes building to Diagonal avenue has a large cantilever in order to highlight the main entrance. This cantilever has been covered up with a false ceiling made with composite panels, producing stripes that emulate the façade. The crowning on all the perimeter of the building has been produced using composite panels, and the 5th floor of the northern building with a complex crowning, also emulating the façade stripes. This project has required a very tight execution planning, due to the project management requirements and the teaching uses of the building own characteristics.



GARCIA FAURA
ARCHITECTURE
IN ALUMINUM,
STEEL AND GLASS

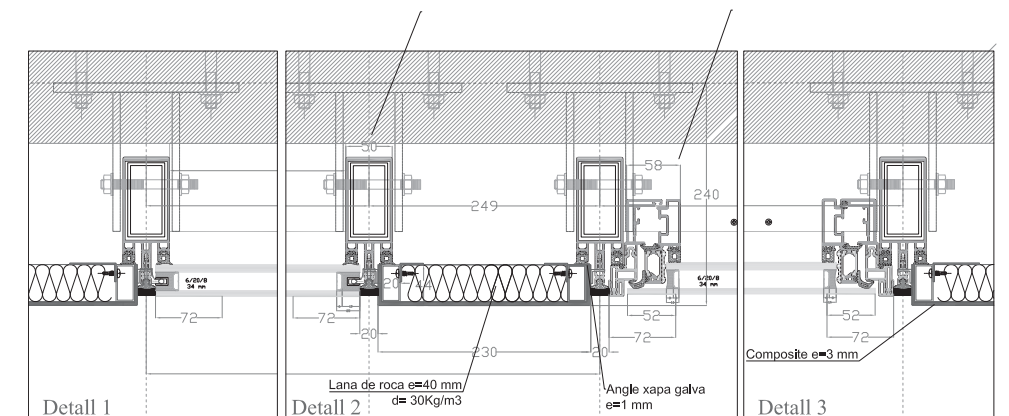



NEW MASSANA SCHOOL

Barcelona (Spain)

GARCIA FAURA
ARCHITECTURE
IN ALUMINUM,
STEEL AND GLASS

NEW MASSANA SCHOOL
Barcelona (Spain)



Year of completion
2017

Architect
Carme Pinós

Works surface area
TEnclosures: 1775 m²
Curtain wall: 168 m²
Solar protection: 168 m.



GARCIA FAURA
ARCHITECTURE
IN ALUMINUM,
STEEL AND GLASS

The project is structured in two blocks: the first, with a facade overlooking Gardunya square, it houses the workshops and the assembly hall, while the second one, which overlooks la calle del Hospital Street, is used for classrooms, offices and a library. From the structural point of view, the workshop area is characterised by large overhangs and the unique solution of the slabs, which are partially visible. Conversely, the second area is constructed from a system of pillars and slabs with solid, reinforced concrete slabs. The building is designed with a series of terraces of varying sizes, as well as a roof located on the fifth floor, used for a range of outdoor activities.

GARCIA FAURA has been commissioned to fabricate and install the 1775 square meters of aluminium enclosures, a total of high-technology 170 doors and windows, and with a slim aesthetic and contemporary design. These are aspects that have been specially taken into account in this project, the focus being a building intended for education in the arts and design. The works are completed with the creation of a curtain wall area and another area equipped with solar protection comprising aluminium tubes.

Mur Cortina E1. Alçat Vist Exterior.

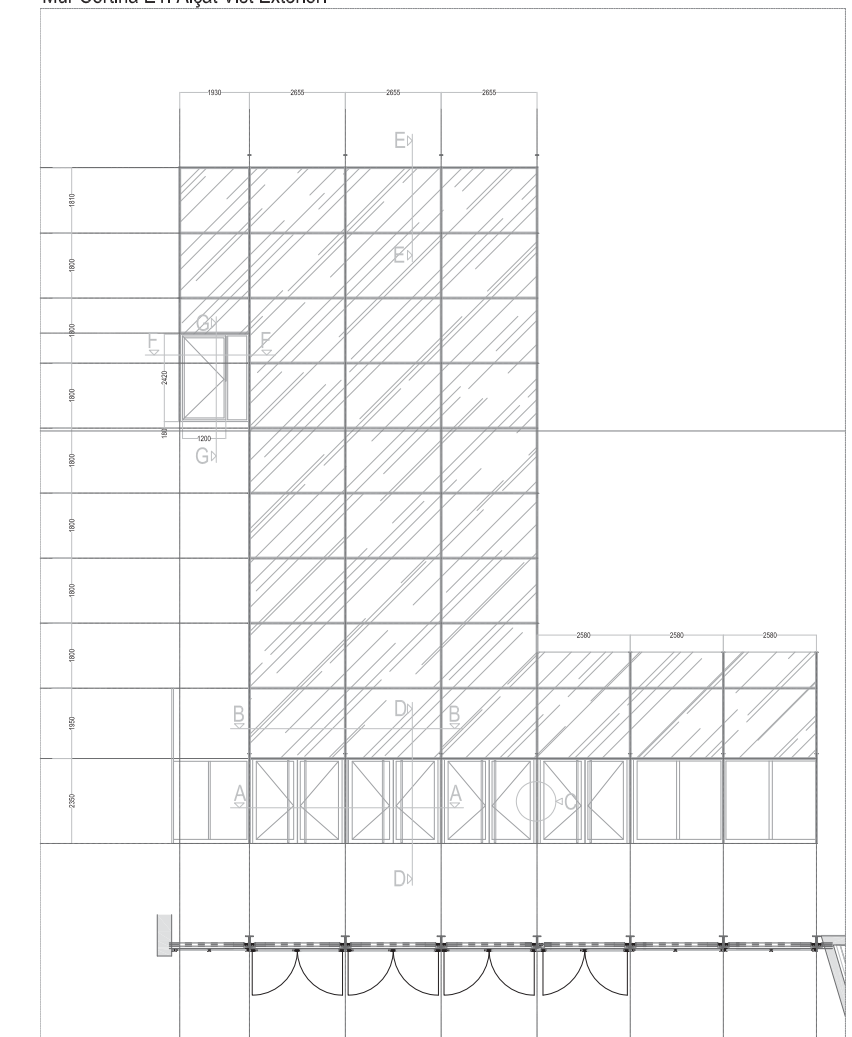



SORLI SHOPPING CENTER

Premià de Mar (Spain)

GARCIA FAURA
ARCHITECTURE
IN ALUMINUM,
STEEL AND GLASS

SORLI SHOPPING CENTER
Premià de Mar (Spain)



Year of completion
2017

Works surface area
Doors and windows: 58 units
Exterior enclosure: 365 m²
Curtain wall: 465 m²
Double skin: 800 m²

The supermarket chain has invested 850,000 euros in this new establishment in Premià de Mar, located at 32, calle Unió, and comprising a surface area of 900 square metres. It is the 112th supermarket from this chain in Catalonia and is based on a commercial model designed to provide solutions that facilitate the purchasing process through the distribution and organization of products. It also has technologies that optimise fresh produce order management using data that allows forecasting of more balanced future sales.

For this project, **GARCIA FAURA** has developed, fabricated and installed a curtain wall and a double skin formed by folded and perforated sheet aluminium trays, which imbue the exterior appearance of the building with uniqueness. In addition, different interior aluminium enclosures and the set of exterior ground-floor enclosures have been fabricated, formed by a lower and upper U-section profile made of steel, with testa glass.



SECCIO VERTICAL

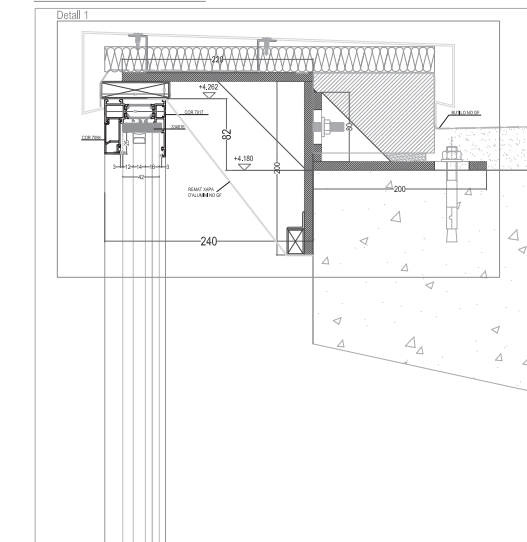

Detall 1

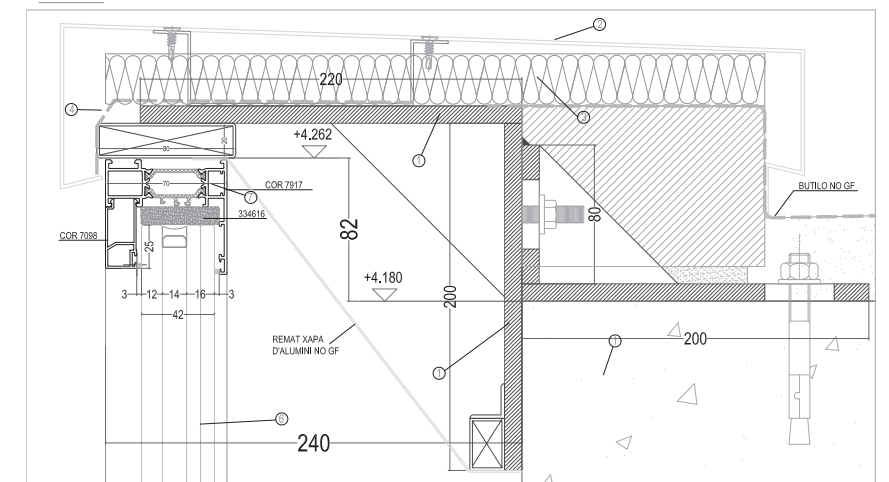

GARCIA FAURA
ARCHITECTURE
IN ALUMINUM,
STEEL AND GLASS



SÚNION SCHOOL EXTENSION

Barcelona (Spain)

GARCIA FAURA
ARCHITECTURE
IN ALUMINUM,
STEEL AND GLASS

SÚNION SCHOOL EXTENSION
Barcelona (Spain)



Year of completion
2016

Architect
Francesc Belart

Works surface area
Enclosures: 138 units
Glass: 434 m²

Private secondary school founded in 1974 on avenida Infanta Carlota, located today on avenida Josep Tarradellas. On 1st September 2009, the school moved its registered offices to avenida de la República Argentina, 85-89. This space has more than 6000 square metres of surface area and is the result of the year-long renovation of a religious school that had closed a few years previously.

The participation of **GARCIA FAURA** in this Súnion School facilities expansion project has consisted in fabricating and installing more than one hundred aluminium enclosures with high technical and acoustic performance, using the profile system from one of the most renowned European suppliers. The alliance between both companies has resulted in the execution of high quality works to fulfil the first level educational requirements of a school of such recognized academic prestige as this one.

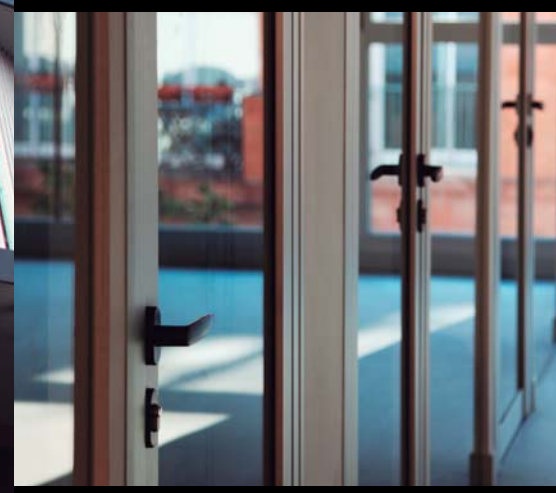

GARCIA FAURA
ARCHITECTURE
IN ALUMINUM,
STEEL AND GLASS



RENAULT DACIA CAR DEALERSHIP

Esplugues de Llobregat (Spain)

GARCIA FAURA
ARCHITECTURE
IN ALUMINUM,
STEEL AND GLASS

RENAULT DACIA CAR DEALERSHIP
Esplugues de Llobregat (Spain)



Year of completion
2016

Architect
Alonso & Balaguer

Works surface area
Aluminium veneer cladding:
2800 m²
Curtain wall: 180 m²

The renovation of the Renault Dacia car dealership in Esplugues de Llobregat, a project by the Alonso & Balaguer studio, added functionality and aesthetics to this old industrial and commercial building. The action considered the exterior intervention to create an outer layer with micro-perforated steel with flat geometry and no edges. This type of intervention not only fulfils a decorative function, but it also brings other values to the building. Combined with a second layer of glazed facade, it multiplies the filtering effects of the radiation, acting as solar and visual control. The exterior metal veneer panels help to filter the sunlight and act as a parasol that avoids direct dazzling inside the building.

GARCIA FAURA signed off on the creation of the curtain wall designed with large open-plan faces, which provide a general exterior view of the vehicles exhibited inside. The perforated veneer cladding was adapted with great precision to a substructure bearing iron pipes, curved in the corners with a cut of the veneer panels that had to be performed with pinpoint precision to be able to create vertical joints that would comply with the guidelines of the architectural project.

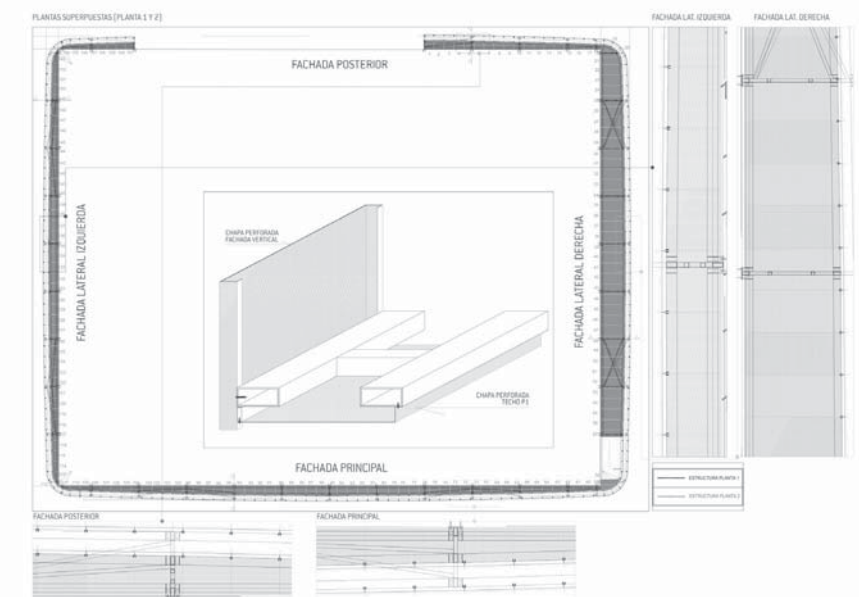

GARCIA FAURA
ARCHITECTURE
IN ALUMINUM,
STEEL AND GLASS



INSTITUTO LA TALAIA

Segur de Calafell (Spain)

GARCIA FAURA
ARCHITECTURE
IN ALUMINUM,
STEEL AND GLASS

INSTITUTO LA TALAIA
Segur de Calafell (Spain)



Year of completion
2016

Architect
Esteve Puigdemongas

Works surface area
Enclosures: 141 units
Veneers, linings and finishings:
2217 m²

The institute is located on a plot covering almost 8000 m² and consists of a useable surface area of 3200 m² distributed over four floors and a courtyard with a 4200 m² sports area, accompanied by a service area. In addition to this facility, La Talaia has study rooms, a library, a 380 m² gymnasium, theatre-room, cafeteria-dining room, concierge service and rooms.

For this building, **GARCIA FAURA** has developed a black aluminium cladding covering 2217 m², which is remarkable for its great resistance and durability, exuding its own exterior aesthetics in contracts to the building. Another highlight is the installation of more than 140 windows, doors and emergency exits designed to guarantee maximum levels of sealing, energy savings and acoustic protection thanks to double glazing and thermal breakage offered by the aluminium profiles.

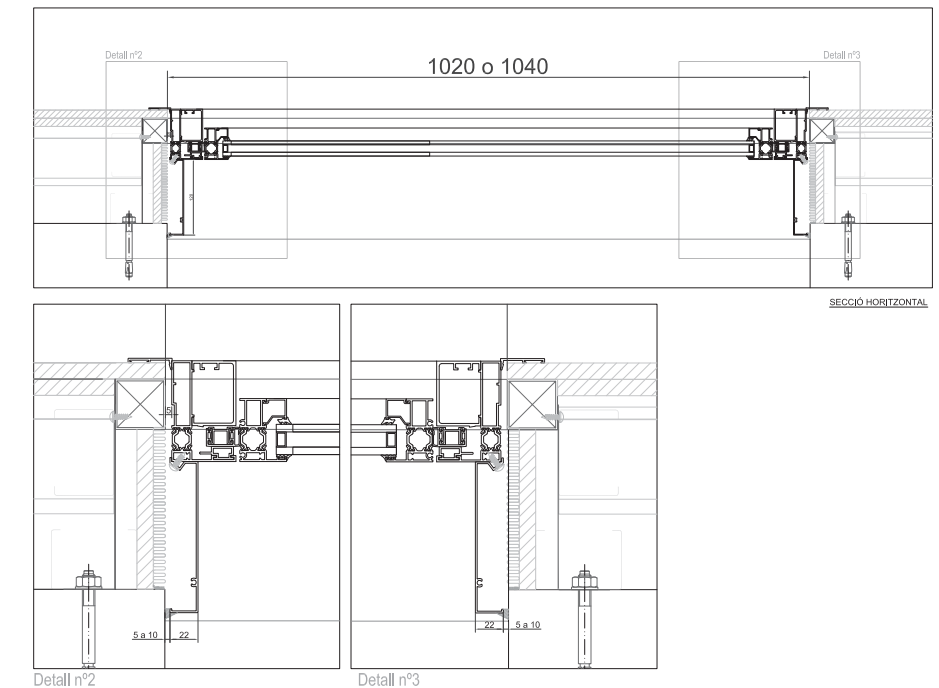

GARCIA FAURA
ARCHITECTURE
IN ALUMINUM,
STEEL AND GLASS



MOLÍ NOU PRIMARY HEALTH CENTRE

Sant Boi de Llobregat (Spain)

GARCIA FAURA
ARCHITECTURE
IN ALUMINUM,
STEEL AND GLASS

MOLÍ NOU PRIMARY HEALTH CENTRE
Sant Boi de Llobregat (Spain)

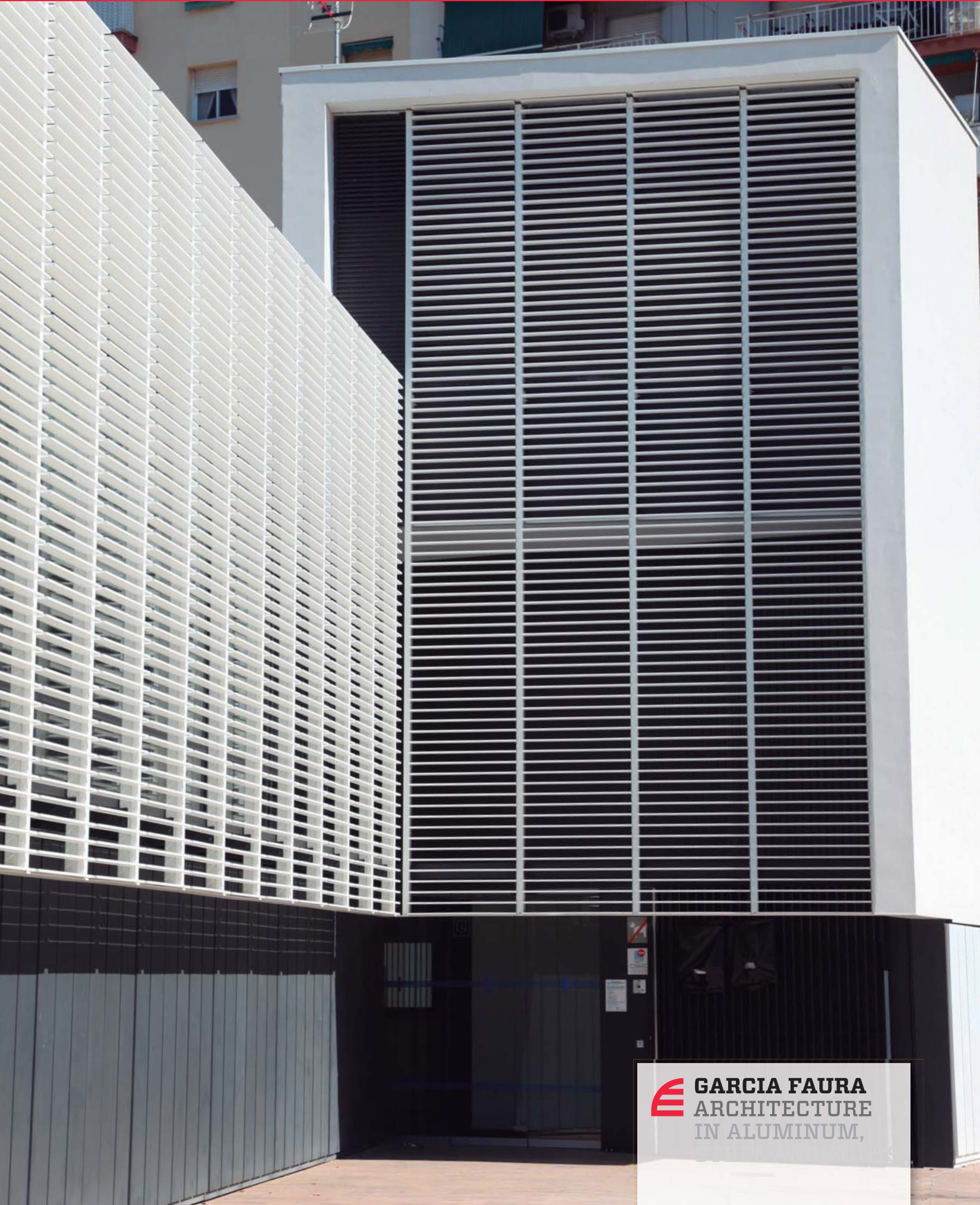

Year of completion
2016

Architect
OP-TEAM ARQUITECTURA SLP X.
Farré, S. Orteu, J. Piferrer

Works surface area
Enclosures: 60 units
Veneer finishing: 110 m²

New primary health centre in Sant Boi de Llobregat, located on an irregularly shaped site with a surface area of 1633 square metres. The building is divided into two floors, with all the services required for a health centre of these characteristics. The architectural project includes the creation of interior yards that serve to ventilate all the rooms in the building and bring light into all the spaces.

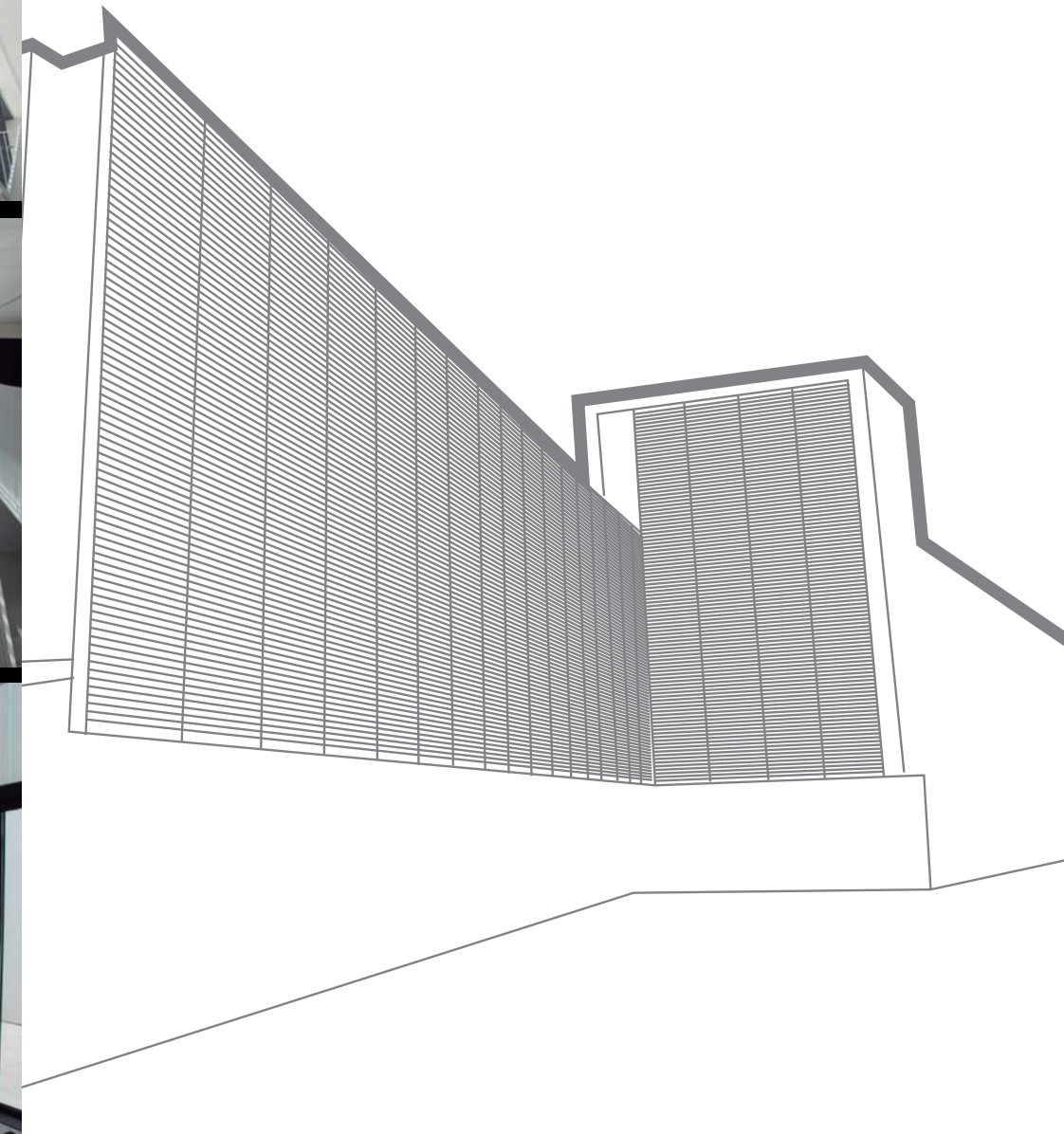

GARCIA FAURA
ARCHITECTURE
IN ALUMINUM,



MERCAGAVÀ MUNICIPAL MARKET

Gavà (Spain)

GARCIA FAURA
ARCHITECTURE
IN ALUMINUM,
STEEL AND GLASS

MERCAGAVÀ MUNICIPAL MARKET
Gavà (Spain)



Year of completion
2015

Architect
Ona Architects

Works surface area
Enclosures: 230 m²

The Gavà Town Council is promoting the construction of the new Municipal Market in the Plaza de Catalunya. The building is erected on the site of the former MercaGavà and has a commercial surface area of 2500 square metres, 1000 of which are assigned to the local produce stands and the rest is occupied by a new Mercadona supermarket. The remaining surface area, up to 12,000 square metres, is used for underground parking, logistics, services and access. The project to improve and modernise the MercaGavà also includes the development of the bordering streets, in such a way that the new market blends into the urban setting better and increases the space for pedestrians.

GARCIA FAURA was in charge of manufacturing and installing the exterior windows and doors of the new building. Almost one hundred doors, windows and, in particular, fixed enclosures providing the facility with a great deal of light, connecting the interior and exterior areas in order to integrate the shopping centre into the urban development. In total, the design incorporates more than 230 square metres of aluminium profile with thermal bridge break, in addition to the automatic access doors. The project has a special meaning for the company, not only because of its magnitude, but because it has been erected in Gavà, where **GARCIA FAURA's** headquarters are located, and where the company has carried out more than one hundred projects.



GARCIA FAURA
ARCHITECTURE
IN ALUMINUM,



TORRE DIAGONAL LITORAL RENOVATION

Barcelona (Spain)

GARCIA FAURA
ARCHITECTURE
IN ALUMINUM,
STEEL AND GLASS

TORRE DIAGONAL LITORAL RENOVATION
Barcelona (Spain)



Year of completion
2016

Works surface area
Glazing: 4000 m²

Building used exclusively as office space that has a surface area constructed with communal elements covering approximately 18,500 m², spread over 14 floors. The upper floor is rectangular in shape and the elevator and service hub is located in the central part, making it highly efficient in use. The curtain wall and the floor plan allow for a high level of light throughout the leasable surface area. The building has a 244-vehicle capacity car park with 59 motorcycle bays.

GARCIA FAURA was commissioned to replace all curtain wall windows in order to improve the thermal efficiency of the property. All the curtain walls were removed in this way, as well as their pressure rollers, removing the existing glazing, and installing the new one. The operation was repeated in the set of glazed units for all 14 floors of the building, which total approximately 4000 square metres of glass. Some mouldings were also replaced and the sealing of the modules located in the corners was improved. The works were undertaken compromising between the works requirements and ensuring that the offices within the building could operate at full capacity on a daily basis.



GARCIA FAURA
ARCHITECTURE
IN ALUMINUM,
STEEL AND GLASS



RENOVATION OF MERCABARNA MANAGEMENT CENTRE

Barcelona (Spain)

GARCIA FAURA
ARCHITECTURE
IN ALUMINUM,
STEEL AND GLASS

RENOVATION OF MERCABARNA MANAGEMENT CENTRE
Barcelona (Spain)



Year of completion
2016

Architect
Xavier Gracia

Works surface area
Enclosures: 530 m²
Curtain wall: 540 m²

The Mercabarna administration and management building dates from 1971 and its facades are masonry work with artificial stone veneer and simple aluminium and glass joinery. The intervention carried out sought to renovate the building's exterior appearance, working on the insulation of all the elements making up the facades and guaranteeing maximum water-tightness.

With this premise, alongside the engineering company in charge of the project, the **GARCIA FAURA** Drawing Office developed a solution of curtain walls and sliding windows and doors that serve to reach this double goal of technical features and aesthetics. In this way, the current joinery was replaced with a new aluminium system with thermal break and double glazing, providing more efficient thermal and acoustic performance. In total, 530 square metres of sliding windows and doors between frameworks. As regards the two main facades, 540 square metres of curtain wall were installed, providing a new more aesthetic cladding, and considerably improving the building's energy classification.



GARCIA FAURA
ARCHITECTURE
IN ALUMINUM,
STEEL AND GLASS

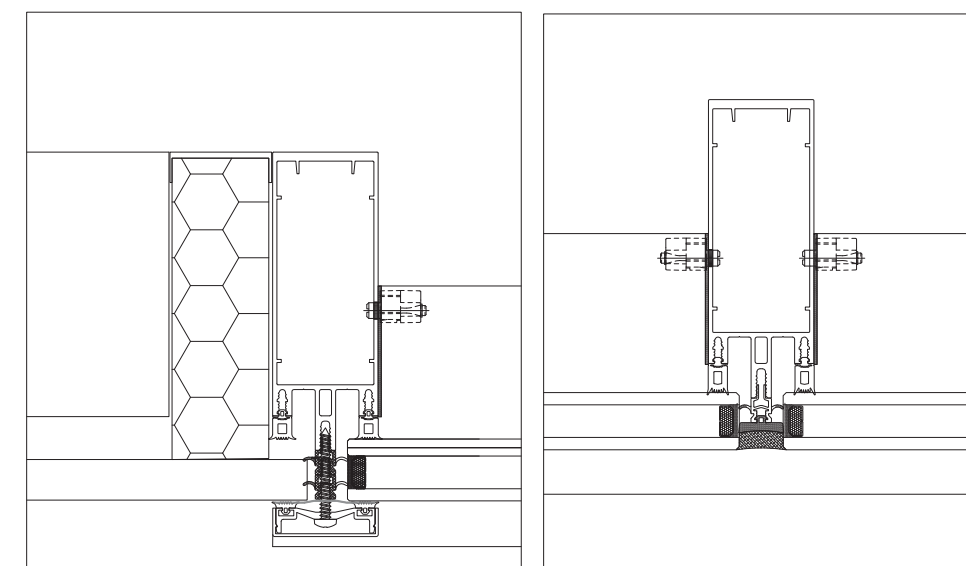



OFI 7 BUSINESS CENTRE

Medellín (Colombia)

GARCIA FAURA
ARCHITECTURE
IN ALUMINUM,
STEEL AND GLASS

OFI 7 BUSINESS CENTRE
Medellín (Colombia)



Ending year
2017

Architect
Rodrigo Fajardo

Works surface area
Glass facades: 510 m²

Enclosures: 3.380 m²



OFI7 La Francia Centro Empresarial is a corporative complex located in Medellín Poblado consisting in a tower 17 stores high used for offices, with auditoriums, conference rooms, terrace and parking lot. This complex is built in a parcel of 2.826 square metres, located 80 metres far from the Avenida El Poblado, in a district with very easy access and close to the transportation modes connecting with the airport. This zone hosts the most representative organization and companies of the Antioque region, as well as distinguished malls and other leisure areas. The building represents a modern, serious and function architecture, thought to become the reference business centre from the so-called Milla de Oro de Medellín.

GARCIA FAURA executes the totality of the enclosure works, consisting in the production and installation of 3.500 square miles of aluminium windows and doors, with European profiles with high technical performance. The executive project combines totally fixed parts with doors and windows with external opening, as well as 500 square miles in the inferior zones executed as glass façades with laminated glass with solar control. The execution of these façades will result in an excellent climatic comfort in the interior of the building and an adequate acoustic attenuation, allowing the normal development of the business inside the complex.

ALZADO VISTA EXTERIOR CARPINTERÍA V23

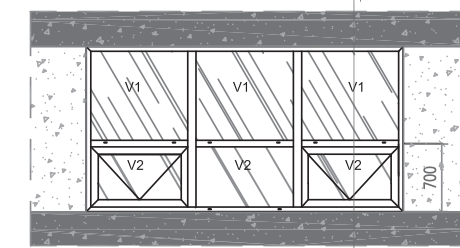

DETALLES SECCIÓN 1

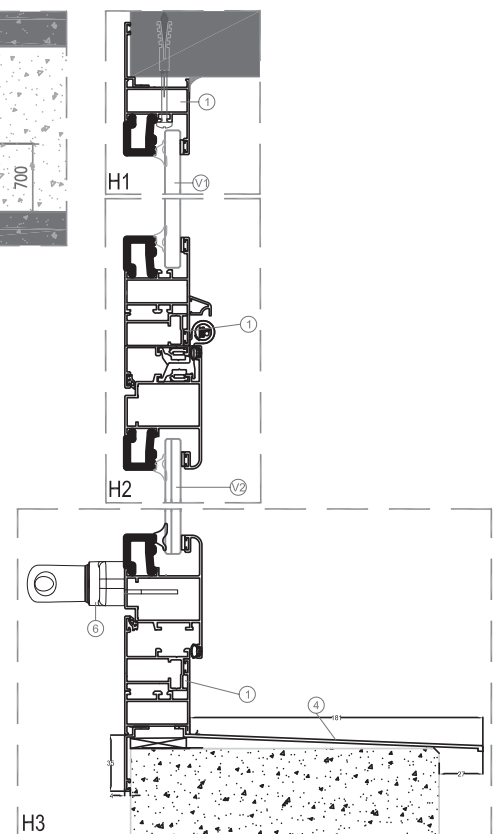

GARCIA FAURA
ARCHITECTURE
IN ALUMINUM,



EXTENSION OF GRÍFOLS FACTORY

Parets del Vallès (Spain)

GARCIA FAURA
ARCHITECTURE
IN ALUMINUM,
STEEL AND GLASS

EXTENSION OF GRÍFOLS FACTORY
Parets del Vallès (Spain)



Year of completion
2015

Architect
INDUS Enginyeria i Arquitectura

Works surface area
Enclosures: 900 m²
Ventilated glazed facade: 50 m²
Composite cladding: 670 m²

The Catalan multinational Grifols, dedicated to the pharmaceutical sector, has constructed a new facility intended for the production of a drug produced from a protein extracted from plasma. The extension of the Parets del Vallès head office, complete with its technically specialised new building installations, will allow progress to be made in the company's consolidation of its position as sector leader.

GARCIA FAURA has undertaken fabrication and installation works for almost 300 aluminium enclosures and over 1000 square metres of facade works, through the combination of glazing, veneers and composite-type panels. A response to the technical and aesthetic requirements was thus envisaged for a building requiring effective levels of insulation and comfort to be able to execute the planned activities with no issues.



GARCIA FAURA
ARCHITECTURE
IN ALUMINUM,
STEEL AND GLASS



IMA CORPORATE HEADQUARTERS

Ripollet (Spain)

GARCIA FAURA
ARCHITECTURE
IN ALUMINUM,
STEEL AND GLASS

IMA CORPORATE HEADQUARTERS
Ripollet (Spain)



Year of completion
2016

Works surface area
Curtain wall: 210 m²
Window and door solutions:
115 m²

Magnetic product manufacturer IMA has invested 3 million euros in the construction of its new warehouse in Ripollet. The building comprises over 5000 square metres and integrates the most efficient technological innovations making it the benchmark company within its sector. With good reason, IMA has become the largest manufacturer of magnets in Spain, with production subsidiaries in China and Italy. The company exports 50% of its trade volume to more than 60 countries.

For this new industrial building, **GARCIA FAURA** has manufactured and installed more than 200 square metres of stick-type curtain wall, with safety glass and high levels of thermal performance. The works have also made provision for the execution of 115 square metres of aluminium enclosures, cladding and composite panel cladding.

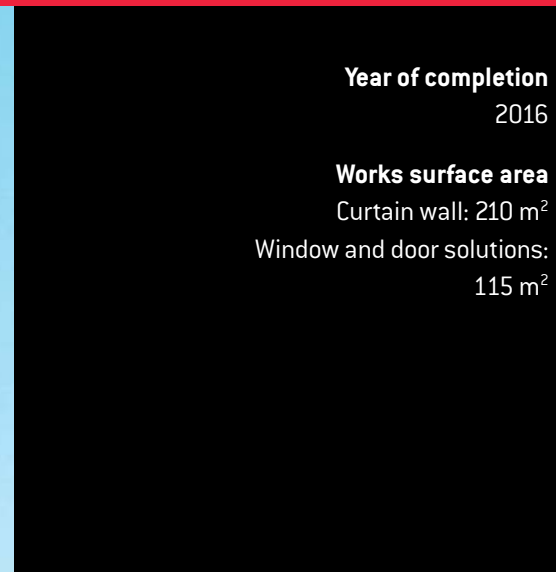

ALÇAT VIST EXTERIOR CARRER TORTUGUER. T16

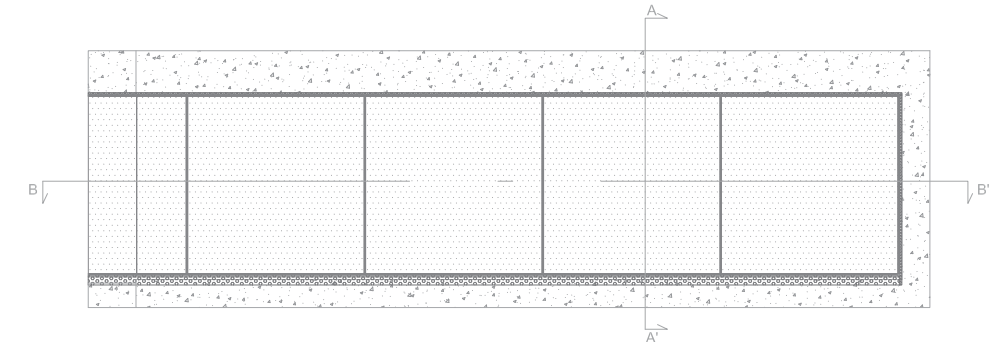

Detall nº1

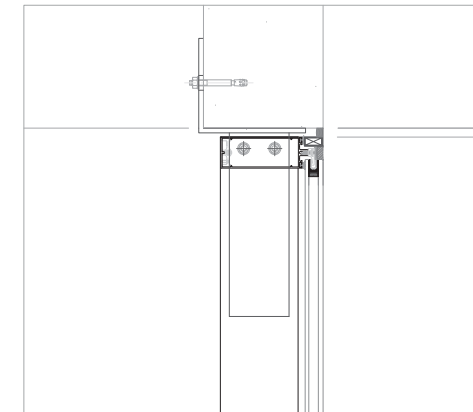

Detall nº2

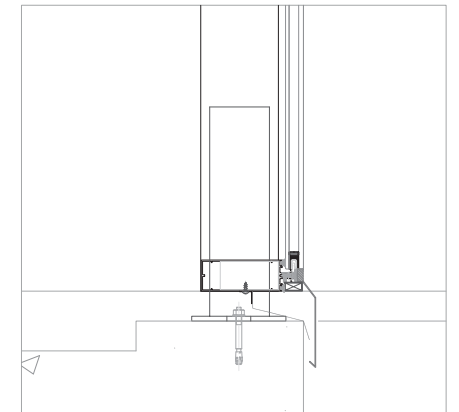

GARCIA FAURA
ARCHITECTURE
IN ALUMINUM,
STEEL AND GLASS



RAILWAY STATIONS SABADELL ESTACIÓ AND PLAÇA MAJOR

Sabadell (Spain)

GARCIA FAURA
ARCHITECTURE
IN ALUMINUM,
STEEL AND GLASS

RAILWAY STATIONS SABADELL ESTACIÓ AND PLAÇA MAJOR
Sabadell (Spain)



Year of completion
2016

Architect
Pere Roda i David Viaplana

Works surface area
Composite cladding: 2130 m²
Aluminium veneer cladding: 2380 m²

In the framework of the project to extend the S2 line of the Catalan railway system, four new stations are being envisaged for the city of Sabadell as well as the renovation of a current station. In the first phase of the project, the installations of the Sabadell-Station were renovated, and the new Sabadell-Plaza Mayor station was built, with everything the construction of a new underground station involves: the building of divides and window and door systems, paving, cladding, the installation of escalators and lifts and the fitting out of electricity, ventilation and sanitary fittings.

GARCIA FAURA's works are notable for the slanted complex lining of the tunnels comprising the staircases to access the train platforms. This lining is composed of perpend precisely adapted to the existing tubular structure, which entails a very complex perimeter assembly. The work in the ventilation towers is also notable, lined with two different types of composite, which match the paving on the platforms. The project was completed with all types of cladding with lacquered chequered veneers (vertical, horizontal faces, entrance doors, emergency doors, etc.) and the grid of pillars and main beams in the entrance to the station from the outside, with composite cladding and highly complex chequered veneers.

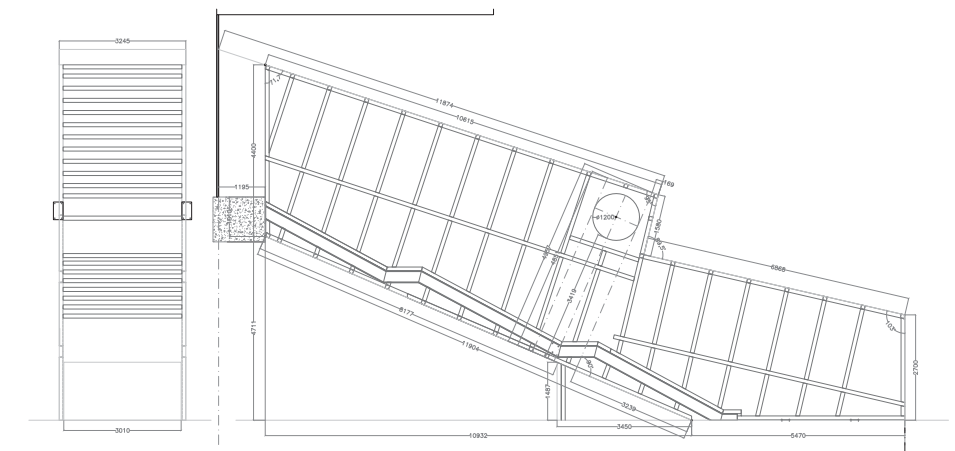

GARCIA FAURA
ARCHITECTURE
IN ALUMINUM,
STEEL AND GLASS



TOWER 4 PORTA FIRAL

Barcelona (Spain)

GARCIA FAURA
ARCHITECTURE
IN ALUMINUM,
STEEL AND GLASS

TOWER 4 PORTA FIRAL
Barcelona (Spain)

Year of completion 2017

Architect
Òscar Tusquets

Works surface area
Glass façade: 1.800 m²
Modular façade: 4.500 m²

Iberdrola Inmobiliario promotes a new phase for one of the most emblematic projects in the south sector of Barcelona. The Porta Firal complex, projected by architect Òscar Tusquets, will consist in 4 business, offices and services towers situated in one of the environments with higher economic production of the city, alongside the Recinte Gran Via Fira de Barcelona, and in the area of influence of Ciutat de la Justícia and Europa Square in L'Hospitalet. With the first tower already finished and functional, the second building (Torre Marina) is developed, with an approximate surface of 20.000 m² and 50 m high. The tower consists in an inferior plinth three stores high, destined to commercial premises, and an upper body destined to offices with 1.200 m² per floor.

GARCIA FAURA executes the façade works of this important project. For the plinth of commercial use, a curtain wall with stick system is developed, with a surface around 1.800 square metres. In the same zone, a curved skylight will be designed, giving a visual badge and allowing the natural light in the building. Regarding the upper body, the curtain wall will consist in a modulated system, with a surface around 4.500 square metres. This façade will have a covering with composite panels, allowing to cover the slab, complemented with zones with deployee.

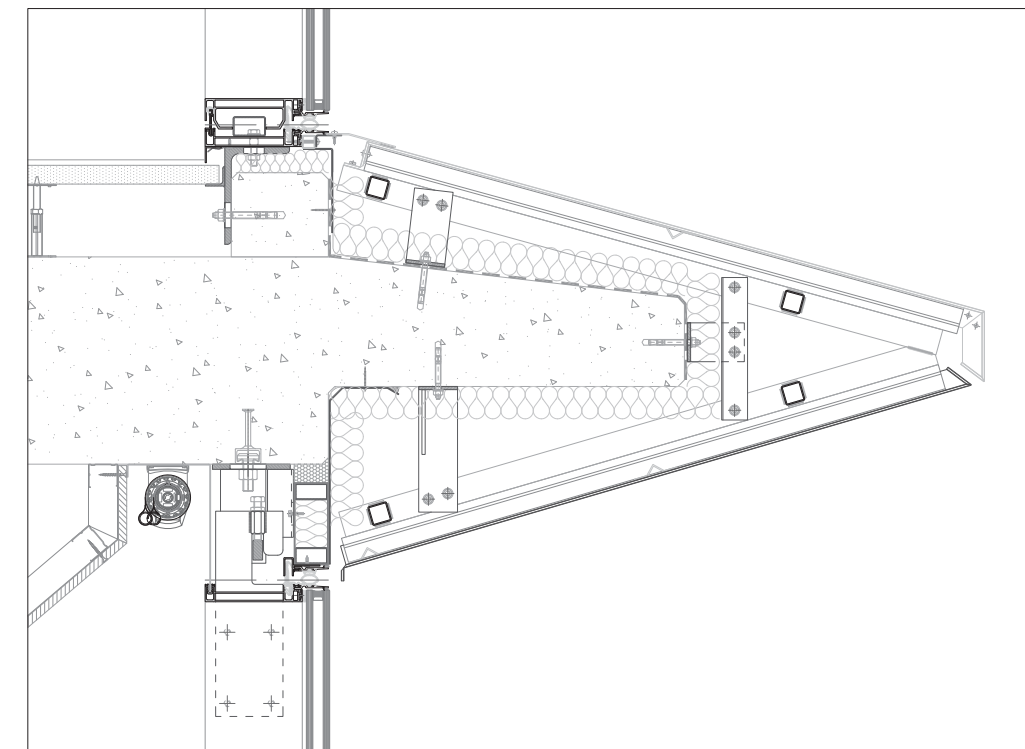

GARCIA FAURA
ARCHITECTURE
IN ALUMINUM,
STEEL AND GLASS



RENOVATION OF THE MELIÀ SOL BEACH HOUSE HOTEL

Sant Eulària des Riu (Spain)

GARCIA FAURA
ARCHITECTURE
IN ALUMINUM,
STEEL AND GLASS

RENOVATION OF THE MELIÀ SOL BEACH HOUSE HOTEL
Santa Eulària des Riu (Spain)

Year of completion
2015

Works surface area
Glass bannister: 850 ml.

Retractable glass curtain: 60 m²
Enclosures: 280 m²

The hotel chain Meliá has renovated this old hotel to convert it into a new concept of holiday accommodation. The renovation project modernised the installations, adapted the internal layout and gave the interior and exterior of the building an entire facelift, turning el Sol Beach House into an important tourist attraction aimed only at adults and committed to a new concept of leisure and relaxation by the sea.

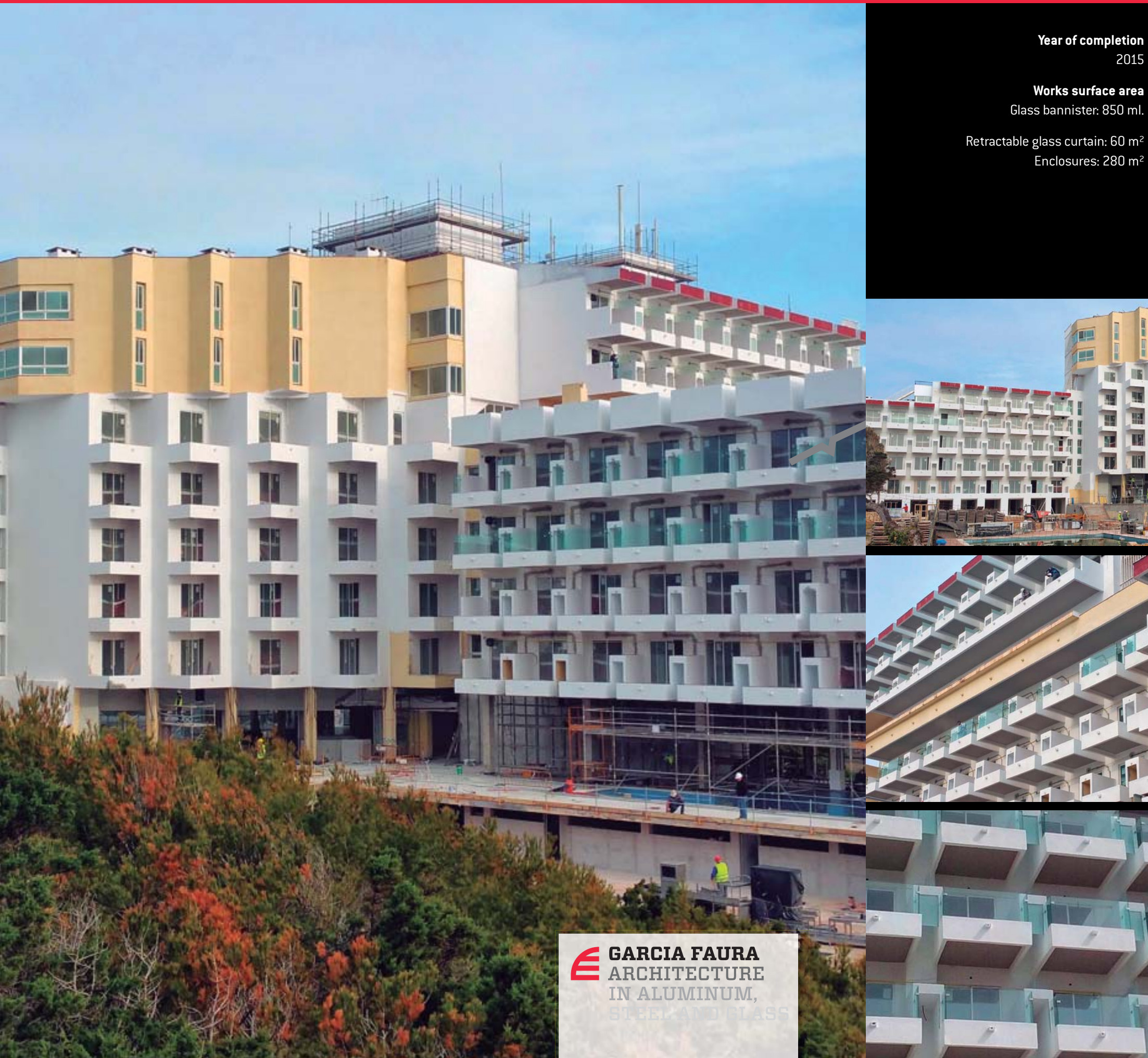

GARCIA FAURA
ARCHITECTURE
IN ALUMINUM,
STEEL AND GLASS





OFFICES DIAGONAL 191-195

Barcelona (Spain)

GARCIA FAURA
ARCHITECTURE
IN ALUMINUM,
STEEL AND GLASS

OFFICES DIAGONAL 191-195
Barcelona (Spain)

Year of completion
2016

Architect
GCA Arquitectes

Works surface area
Fachada modular: 13.600 m²
Lamas protección solar: 11.400 m²
Muro cortina: 420 m²
Revestimiento de chapa
grecada: 1.000 m²

New office building in the economical district 22@ in Barcelona. The project consists in two towers, 10 and 17 stores high, connected through a central atrium. There is a surface of 21.000 square metres, and the capacity can reach up to 800 workers. Architecturally, the project, developed by GCA Architects, presents a façade surface covered totally in glass, with clear appearance, covered with dark vrise-soleils. This building is projected to obtain the LEED Gold qualification, meaning a 30% reduction in the energetic waste compared to a normal building. This will be a space full of natural light and totally transparent, connected to an external space with high urbanistic value.

GARCIA FAURA has executed a façade of high complexity. The modulated type curtain wall has a second skin with horizontal slats for solar protection. Both the modules and the second skin have been specifically designed for this project, and in order to ensure that the high technical requirements are met, various samples have been tested. The whole modulated façade is surrounded by metallic eaves, formed by lacquered aluminium sheets, integrated in the modules. The atrium has been executed as well, composed by two identical curtain wall façades, including a glass canopy and access through a revolving door. The atrium is completed with a system for the smoke extraction. All 13.600 square metres were installed in only 3 months.

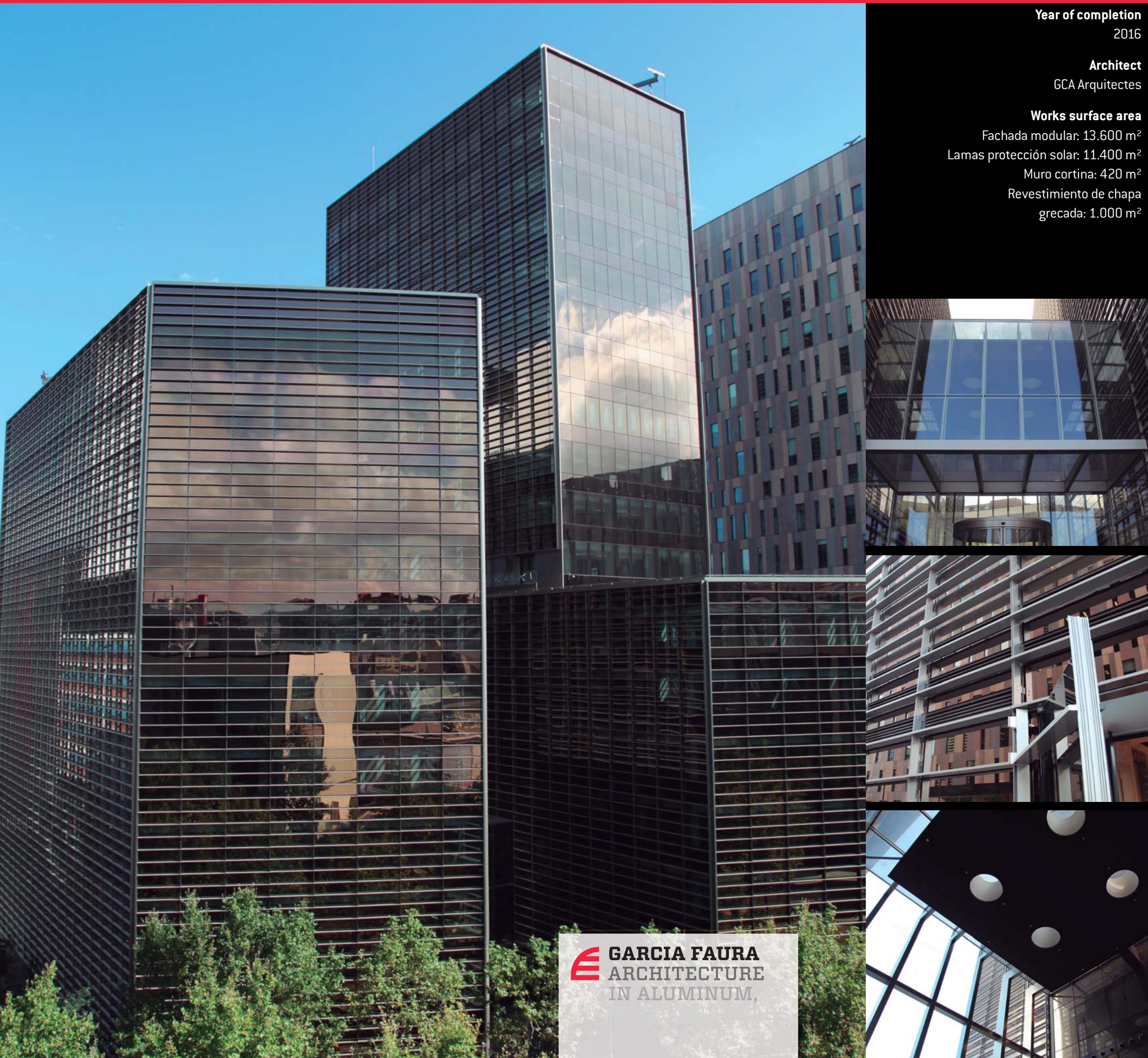

GARCIA FAURA
ARCHITECTURE
IN ALUMINUM,

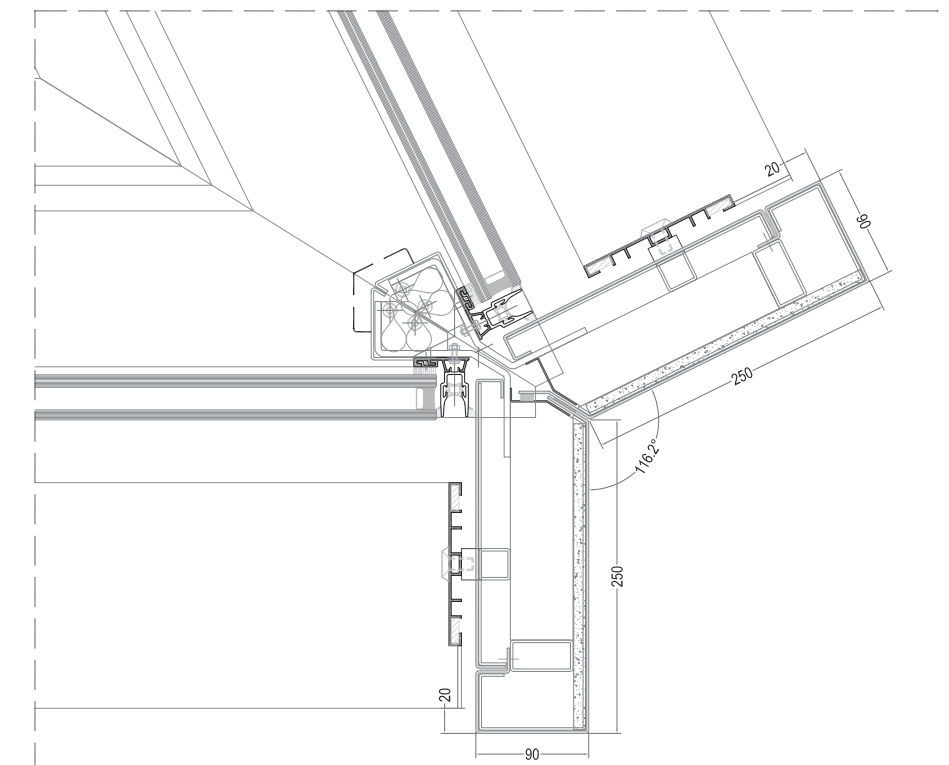



LA BENAULA SCHOOL

Caldes de Malavella (Spain)

GARCIA FAURA
ARCHITECTURE
IN ALUMINUM,
STEEL AND GLASS

LA BENAULA SCHOOL
Caldes de Malavella (Spain)



Year of completion
2015

Architect
Ensenyat-Tarrida architects

Works surface area
Enclosures: 445 m²

The new school in Caldes de Malavella is located on a site of approximately 10,000 square metres, of which the building occupies a little over half. The rest of the site is reserved for the future construction of a secondary school, which will mean both centres can share common areas and thereby reduce the construction and management costs. The new school building is located in an area subject to flooding, but of very high environmental quality, between two roads and the woods. The project is developed in a U shape and has three elevated volumes which in turn define the indoor play area.

GARCIA FAURA undertook the fabrication and installation of the building's windows and doors. A total of 445 square metres fabricated with aluminium profiles with high technical features and aesthetics that blend with the construction project. Seeking the maximum wellbeing and comfort for the end users of the installations: the students and teachers of the education centre.



GARCIA FAURA
ARCHITECTURE
IN ALUMINUM,
STEEL AND GLASS

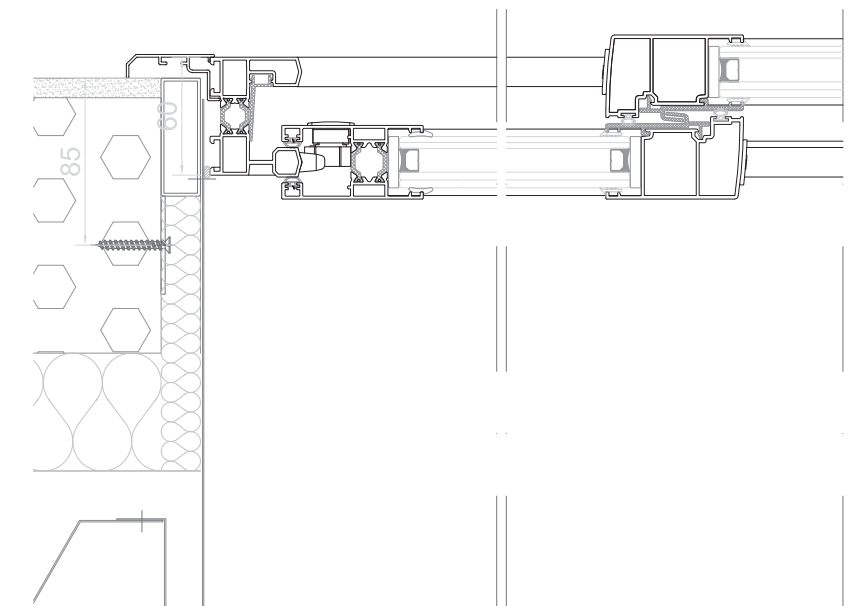



UPC DIAGONAL BESÒS BUILDING A

Barcelona (Spain)

GARCIA FAURA
ARCHITECTURE
IN ALUMINUM,
STEEL AND GLASS

UPC DIAGONAL BESÒS BUILDING A
Barcelona (Spain)

Year of completion
2016

Architect
José Antonio Martínez Lapeña

Works surface area
Enclosures: 10.000 m²

The new Diagonal-Besòs Campus of the Polytechnic University of Catalonia (UPC) is called to become educational centre of the country, specialized in Industrial Engineering. This space -close to 150.000 square meters- will become the meeting point for the educational and research community, being the location of various educational buildings, as well as research laboratories and other services, as the Catalan Institute for Energy Research or a university residence, among others.

Up to now, **GARCIA FAURA** has participated in the Building A, which will be destined to a mixed use, combining teaching, research and other college services. This project, by the architect José Antonio Martínez Lapeña, with 20.000 square metres of buildable roof, combines different heights, up to a maximum of 10 stores. The works of the **GARCIA FAURA** have focused of the production and installation of 10.000 square metres of aluminium carpentry and glass, doors and windows, both including tilt-turn and sliding openings, depending on the needs and uses of every space. The set of windows and doors of the whole building, anodized with silver matte finish, are made with aluminium profiles with thermal break and high performance glass.



GARCIA FAURA
ARCHITECTURE
IN ALUMINUM,
STEEL AND GLASS

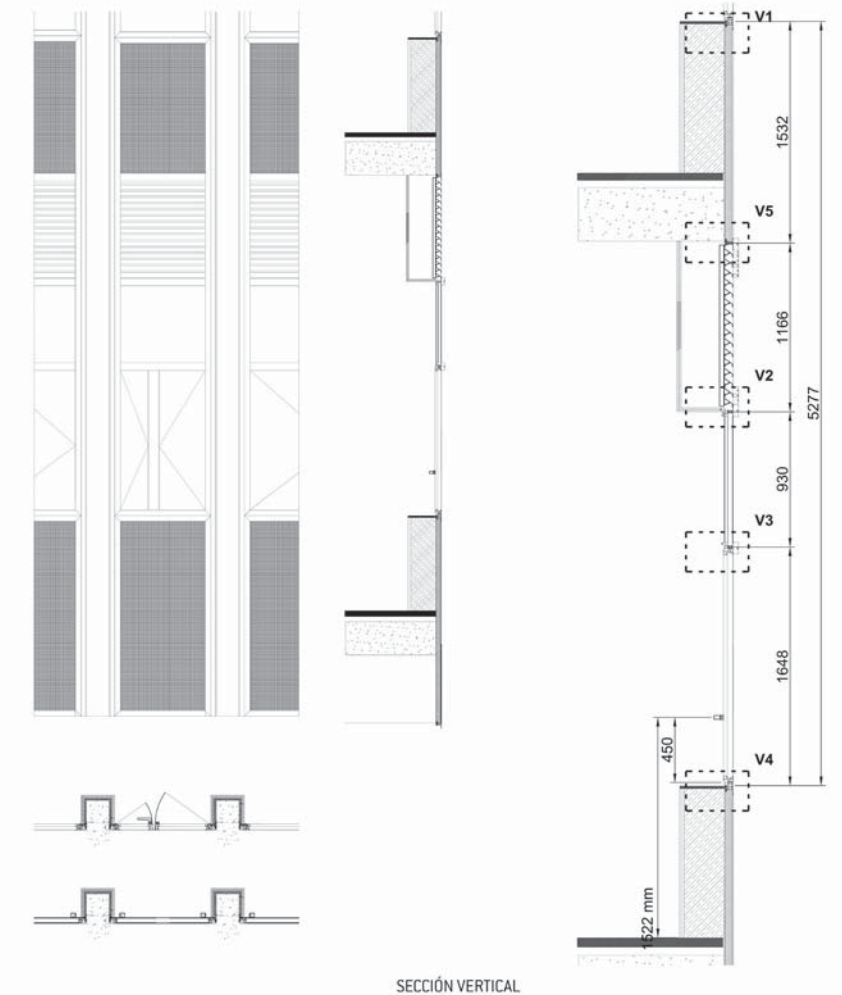



LLORET LOCAL POLICE STATION

Lloret de Mar (Spain)

GARCIA FAURA
ARCHITECTURE
IN ALUMINUM,
STEEL AND GLASS

LLORET LOCAL POLICE STATION
Lloret de Mar (Spain)



Year of completion
2015

Architect
CPVA Architects

Works surface area
Enclosures: 240 m²
Facade cladding: 175 m²
Crowning and finishing: 950 ml



New local police and civil protection service of the Lloret de Mar town council, built as a workplace for 140 people, with the typical buildings and services in a police office. The new unique building has meant the service has been moved from the old building in the centre of the town. The triangular shape of the building rises naturally as a response to the converging of the border of the car parks, the pine forest and the main facade that points toward the road. The view of the building from that main facade symbolises the bow of a boat.

In this project, predominantly vertical window and door solutions were manufactured and installed, in narrow strips adapted to the stone cladding on the facade. They create a minimalist appearance on account of the narrow section of the profiles, which has hidden sashes. The building's triangular shape also required complex composite cladding on the entire exterior roof of the main facade.

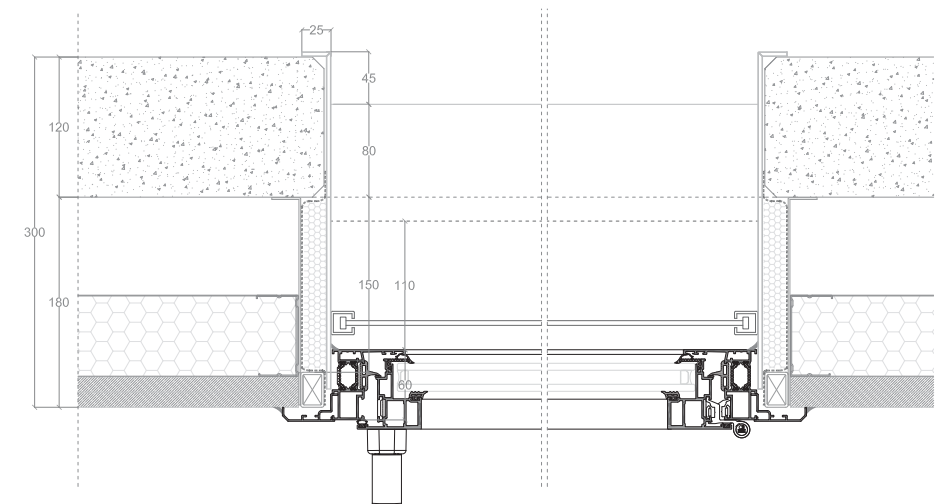

GARCIA FAURA
ARCHITECTURE
IN ALUMINUM,
STEEL AND GLASS



MONTBAIG FIRST AID FACILITY

Viladecans (Spain)

GARCIA FAURA
ARCHITECTURE
IN ALUMINUM,
STEEL AND GLASS

MONTBAIG FIRST AID FACILITY
Viladecans (Spain)

Year of completion
2016

Architect
Josep Camps i Olga Felip

Works surface area
Facade: 110 m²
Enclosures: 100 units

New primary health centre in the city of Viladecans, located beside the Torre Roja park and the new Podium sports complex. The new Montbaig primary health centre consists of more than 2763 square metres, distributed over a ground floor and two storeys. The centre provides the usual healthcare services as well as sexual and reproductive health services and mental health services.



GARCIA FAURA
ARCHITECTURE
IN ALUMINUM,
STEEL AND GLASS



TORRE DIAGONAL RESIDENTIAL PROMOTION

Barcelona (Spain)

GARCIA FAURA
ARCHITECTURE
IN ALUMINUM,
STEEL AND GLASS

TORRE DIAGONAL RESIDENTIAL PROMOTION
Barcelona (Spain)



Year of completion
2016

Works surface area
Enclosures: 825 units
Glass: 2760 m²

It is a block of 125 dwellings spread over a total of 26 floors, with a communal area that has, amongst other things, a swimming pool on the building roof. The interest raised by the construction of this block of buildings has been such that more than 95% of the units had been sold before the completion of the works.

Due to the specifications of the tower, both in terms of location and height, **GARCIA FAURA** has designed doors and windows with thermal bridge breakage and high technical performance, to increase its levels of insulation and resistance to weather conditions. Hinged and sliding openings are combined, according to the use of each enclosure and its distribution within the building as a whole. Furthermore, the enclosures have a dual-colour finish, with the internal profiles in white and the outside face in grey, in order to integrate with the specific aesthetics of the project.



GARCIA FAURA
ARCHITECTURE
IN ALUMINUM,
STEEL AND GLASS



RENOVATION OF MONTSERRAT SCHOOL

Martorell (Spain)

GARCIA FAURA
ARCHITECTURE
IN ALUMINUM,
STEEL AND GLASS

RENOVATION OF MONTSERRAT SCHOOL
Martorell (Spain)



Year of completion
2015

Architect
Rodrigo Alaminos

Works surface area
Enclosures: 40 units
Veneer finishing: 125 m²
Curtain wall: 10 m²

Renovation of a building designed by Josep Lluís Sert in 1935 and catalogued as a municipal historical heritage: It needed to be renovated to be able to be used as a secondary education centre. The works were performed in two of the three modules making up the building. They underwent a profound renovation which led to the creation of the study spaces required for the new use.



GARCIA FAURA
ARCHITECTURE
IN ALUMINUM,
STEEL AND GLASS





MERCABARNA CAR PARK

Barcelona (Spain)

GARCIA FAURA
ARCHITECTURE
IN ALUMINUM,
STEEL AND GLASS

MERCABARNA CAR PARK
Barcelona (Spain)



Year of completion
2015

Architect
Cantalops Vicente architects

Works surface area
Enclosures: 280 m²

Located on Calle Mayor, the main thoroughfare of the site, and in the main commercial area, the new Mercabarna car park has three floors for cars, and a ground floor, measuring 700 m², for commercial use. In total, there are 305 new spaces, making it one of the fundamental elements of the new Mercabarna Mobility Plan, a project promoted by the site management and the Association of Dealerships and that was designed to adopt measures to facilitate the circulation and movement of trailers, lorries and vans and allow pedestrians to safely move around the interior of this large food estate.

Considering the end use of the installation, the parking of vehicles, the works were limited to the manufacturing and assembly of all the aluminium windows and doors in the structure. From access and services doors, to windows and French windows.



GARCIA FAURA
ARCHITECTURE
IN ALUMINUM,
STEEL AND GLASS



BAGES SUD FUNERAL HOME

Sant Vicenç de Castellet (Spain)

GARCIA FAURA
ARCHITECTURE
IN ALUMINUM,
STEEL AND GLASS

BAGES SUD FUNERAL HOME
Sant Vicenç de Castellet (Spain)

Year of completion
2014

Architect
Barceló Balanzó
Plasencia Arquitectura

Works surface area
Enclosures: 145 m²

Located on an 800-square metre site, the new funeral home in Sant Vicenç de Castellet is characterised for being a functional building that guarantees privacy, considering its use. In this regard, the visitation rooms have private interior terraces, as well as a large central patio for communal use. To make the most of the natural light, large windows and glass openings were used, maintaining a sense of privacy while staying in contact with the exterior.

To satisfy this need for maximum interior luminosity, the works carried out by **GARCIA FAURA** focused on the development, manufacturing and installation of several zones with butt joint double glazed facade, installed with hidden runners on the floor and the roof. The works were completed with the installation of aluminium doors with an anodised black matt finish.

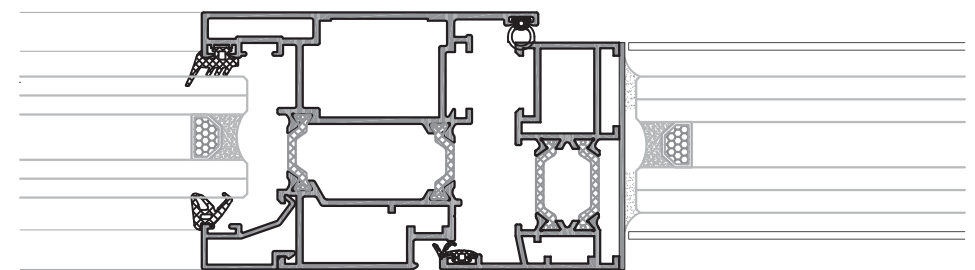

GARCIA FAURA
ARCHITECTURE
IN ALUMINUM,
STEEL AND GLASS



ESTEVE ALBERT SECONDARY SCHOOL

Sant Vicenç de Montalt (Spain)

GARCIA FAURA
ARCHITECTURE
IN ALUMINUM,
STEEL AND GLASS

ESTEVE ALBERT SECONDARY SCHOOL
Sant Vicenç de Montalt (Spain)



Year of completion
2015

Architect
Estudi Nao + José María Gutiérrez

Works surface area
Enclosures: 100 units



The new public institute of Sant Vicenç de Montalt has a floor space area of 4425 square metres, divided into three floors and a yard with a surface area of 5000 square metres. The new building boasts the services and commodities of a newly built centre, and even more so, bearing in mind that the former installations were in prefabricated modules. With the new building, the centre now has classrooms, spaces for administrative functions, exterior sheltered areas, recreation areas, a cafeteria, changing rooms and a library. In addition, the building has a gym that measures 300 square metres and an exterior sports court that measures 1400 square metres.

GARCIA FAURA was in charge of the interior and exterior windows and doors in the building. In this regard, one hundred doors and windows were fabricated, in accordance with the usage needs of the installation. The windows and doors combine profiles with highly technical features and composition glass adapted to the thermal and acoustic insulation needs of this construction project.

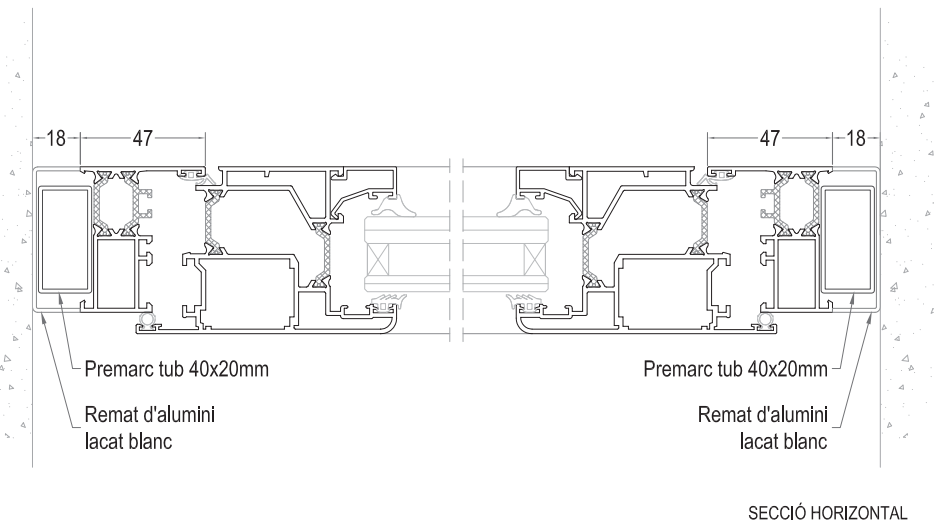

GARCIA FAURA
ARCHITECTURE
IN ALUMINUM,
STEEL AND GLASS

Photos: José Hevia



CONTROL TOWER EL DORADO AIRPORT

Bogotá (Colombia)

GARCIA FAURA
ARCHITECTURE
IN ALUMINUM,
STEEL AND GLASS

CONTROL TOWER EL DORADO AIRPORT
Bogotá (Colombia)



Ending year
2016

Architect
Bruce S. Fairbanks / INECO

Works surface area
Glass façade: 1.720 m²

Enclosures: 330 m²

Composite covering: 700 m²

New Control Tower for El Dorado International Airport, 89 metres high, composed by three bodies. The inner body is covered through an external skin formed by metallic structure made by 20 helicoidal steel tubes with rectangular section which form an external mesh forming a frustum. The metallic and concrete structures are connected by steel beams in order to resist the seismic and wind actions. The upper body, 6 stores high, supports the lighthouse of the control cabin for the air traffic.

GARCIA FAURA has fabricated and installed around 3.000 square miles of panels, enclosures, skylights and glass façades both of conventional type, rhomboidal or inclined. The singular design has increased the technical complexity as well as the execution of the project, since it combines different materials, with various inclinations and works at different heights. The new tower should meet a series of technical requirements, such as wind speeds up to 380 km/h acting on the façade. This is one of the reasons why the glass on the upper part reaches weights up to 600 kg, which will allow to meet the high acoustic attenuation required by the project.



GARCIA FAURA
ARCHITECTURE
IN ALUMINUM,
STEEL AND GLASS

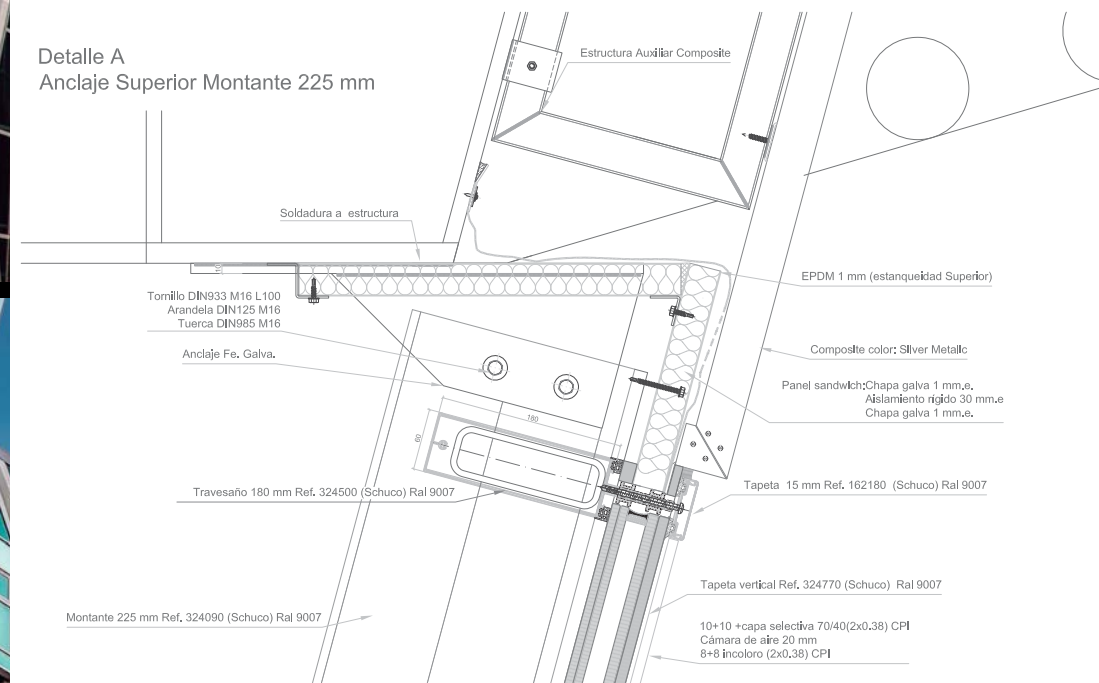



AERONAUTICAL MANAGEMENT CENTRE

Bogotá (Colombia)

GARCIA FAURA
ARCHITECTURE
IN ALUMINUM,
STEEL AND GLASS

AERONAUTICAL MANAGEMENT CENTRE
Bogotá (Colombia)



Ending year
2015

Architect
Esteban Rodríguez Soto
Sener - Incoplan

Works surface area
Glass façade: 2.100 m²
Enclosures: 884 m²



GARCIA FAURA
ARCHITECTURE
IN ALUMINUM,
STEEL AND GLASS

Headquarters of the new Colombian Aeronautical Management Centre (CGAC) that will house the provision and integral and automated management of the air traffic of the country, with a total built area of 9.351 m². The CGAC is conceived from a circular development as an independent complex consisting in four buildings for the different uses (Control Centre, Management, Technical Area and Rest Area), articulated through a distributor or link located at the centre of the complex. Each one of those buildings is two stores high over the ground level except for the Control Centre, which is three stores high.

The works performed by **GARCIA FAURA** consist in the execution of the polygonal glass façade enveloping the central corridor, as well as the production and installation of the windows with thermal break profiles and tilt-turn opening. The light façade consists in a stick system with caps particular for polygonal façades. The forms and designs of the various elements of the project stand out for their complexity, forcing **GARCIA FAURA** to exploit its potential for the development of light façades through 3D technology.

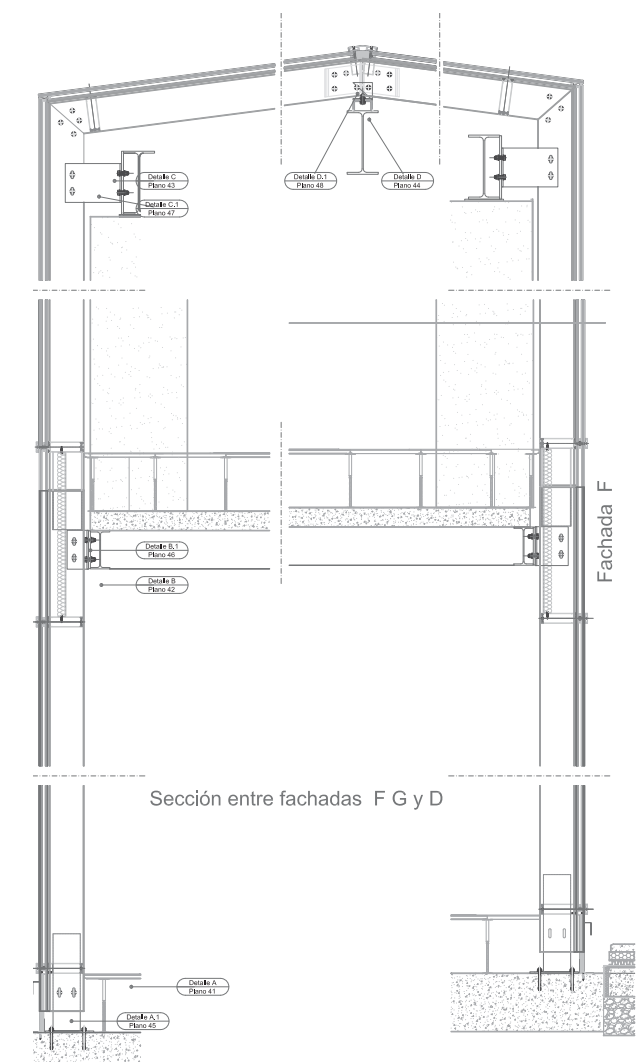



SMART ROOM HOTEL BARCELONA

Barcelona (Spain)

GARCIA FAURA
ARCHITECTURE
IN ALUMINUM,
STEEL AND GLASS

SMART ROOM HOTEL BARCELONA
Barcelona (Spain)



Year of completion
2015

Architect
INDUS Enginyeria i
Arquitectura

Works surface area
Aluminium sheets: 45 m²
Enclosures: 230 m²

Former production facility for decorative figures, completed renovated to transform it into a new low-cost hotel. The project sought to make the most of the existing infrastructure, reorganising the layout and providing comfortable solutions for future guests. The result is a hotel with 56 rooms, designed with a clean and minimalist style. The building has a small Mediterranean-style terrace out the back, as well as different communal rooms for customers, but also as an alternative for holding professional events.

For the works in this building, **GARCIA FAURA** had to adapt to one of the main premises of the project: quality products but in reduced execution periods that minimise the end cost of the work and make feasible the reduced prices of the accommodation that the hotel offers as its main selling point. The company's task consisted in manufacturing and installing windows and doors in the bedrooms, as well as a small zone of aluminium sheets.

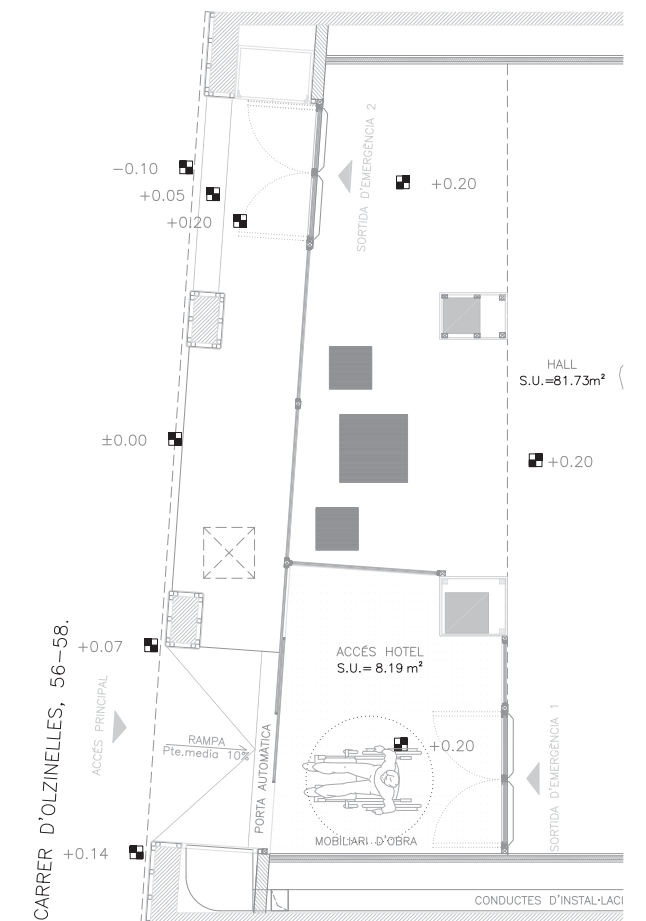

GARCIA FAURA
ARCHITECTURE
IN ALUMINUM,
STEEL AND GLASS



BUILDING CALABRIA 66

Barcelona (Spain)

GARCIA FAURA
ARCHITECTURE
IN ALUMINUM,
STEEL AND GLASS

BUILDING CALABRIA 66
Barcelona (Spain)



Year of completion
2015

Architect
Laviña - De la Villa Arquitectura

Works surface area
Aluminium rims: 250 units
Glazing: 1700 m²
Aluminium cladding: 300 m²
Crowning and veneer: 800 m²

Renovation works in an old unused building, to set it up for municipal services and neighbourhood installations. 11,000 square metres to be developed into a centre for the exchange of citizens' concerns, with a high number of joint management spaces. A new hub for a continuously changing neighbourhood. The works have involved the reinforcement and modification of the existing structure in accordance with the location of the new vertical communication hubs, a new roof and facilities, as well as the complete renovation of the set of facades, which have resulted in building energy savings of 25%.

On the main façade, coated extruded aluminium perimeter frames were installed as joinery mouthpieces, together with a canopy lined with a composite panel. On the rear facade, **GARCIA FAURA's** works also consisted in installing these same perimeter frames, as well as lining the entire facade with silver anodised veneers on a substructure of galvanised steel. Lastly, a third facade was also built with anodised metal trays and pre-glued insulation, screwed onto a galvanised steel structure.

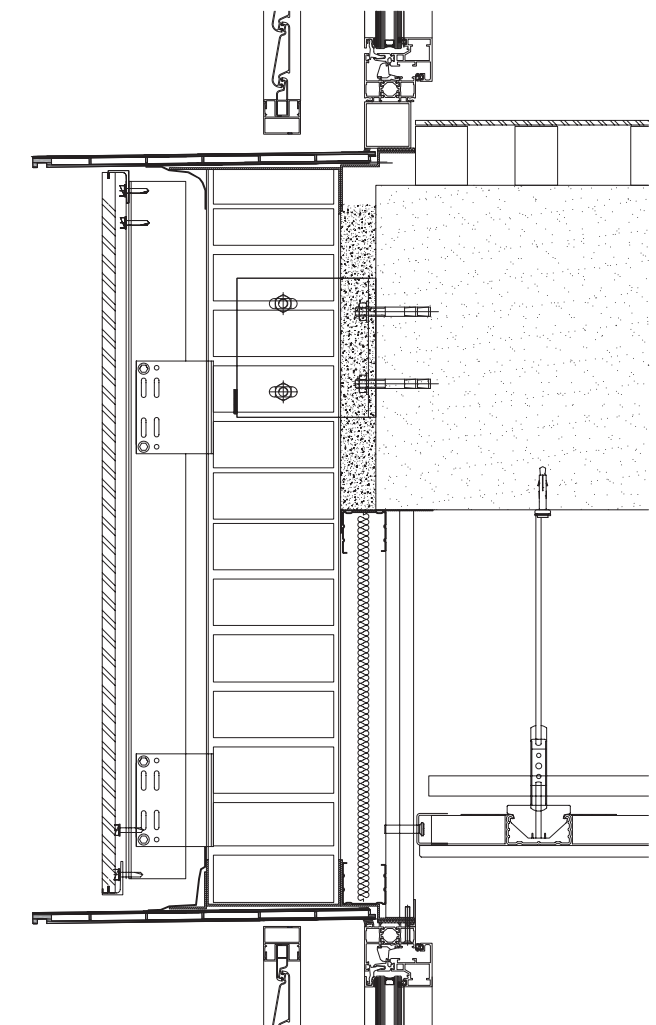
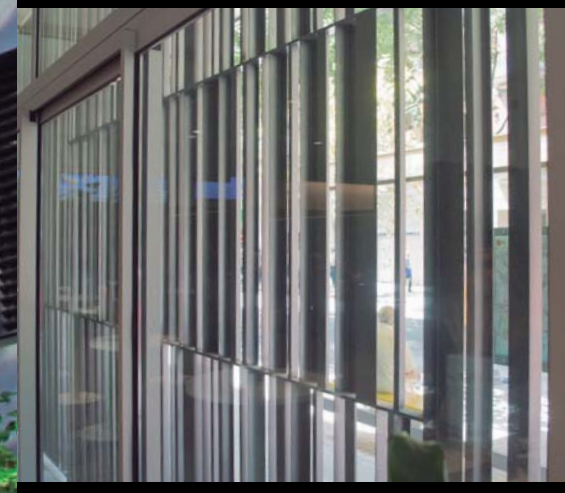

GARCIA FAURA
ARCHITECTURE
IN ALUMINUM,
STEEL AND GLASS



PALLEJÀ MUNICIPAL MARKET

Pallejà (Spain)

GARCIA FAURA
ARCHITECTURE
IN ALUMINUM,
STEEL AND GLASS

PALLEJÀ MUNICIPAL MARKET
Pallejà (Spain)



Year of completion
2015

Architect
Guillermo Muñoz
GRAM Arquitectura

Works surface area
Enclosures: 570 m²
Aluminium veneer cladding: 220 m²

The town of Pallejà has renovated its municipal market, which was located in a building that had become too small and old. The new market not only consists of a new building, but has also led to a new boost of local commercial activity in the centre of the town. A central building with 10 interior stands and 8 exterior stands was built, as well as an additional services and equipment area, and a new supermarket and car park for 195 vehicles.

GARCIA FAURA fabricated and installed more than 570 square metres of aluminium and glass windows and doors, both on the exterior facade of the ground floor and on the upper floors. This exterior appearance was completed with the metal veneer cladding that gives the building a more urban and contemporary look. The interior brightness is one of its most characteristic features, connecting the interior space with city life.



GARCIA FAURA
ARCHITECTURE
IN ALUMINUM,
STEEL AND GLASS



EL NACIONAL RESTAURANT

Barcelona (Spain)

GARCIA FAURA
ARCHITECTURE
IN ALUMINUM,
STEEL AND GLASS

EL NACIONAL RESTAURANT
Barcelona (Spain)

Year of completion
2014

Architect
Estudi Pulsen Interiorismo: Lázaro
Rosa-Violán

Works surface area
Steel enclosures: 185 m²

El Nacional is the largest gastronomic space in the entire Spanish state. 3500 square metres uniting several gastronomic proposals in one same building, with room for 770 guests. The macrospace is located within a block of the famous Barcelona Eixample, in a former modernist exhibition hall, built at the end of the 19th century, and used as a car park since the mid-20th century. The architectural project has safeguarded one of the most interesting elements in the building: the Catalan vaulted ceiling, and showcases one of the most noble materials typically used in modernism: iron.

In this work, GARCIA FAURO fabricated and installed all the exterior windows and doors, which combine aluminium and stainless steel, with particular emphasis on soundproofing, since the project required a threshold of 39 decibels. Maximum insulation profiles were combined with high performance glass panes, always following the aesthetic parameters that make the architectural and interior design project so unique.



GARCIA FAURA
ARCHITECTURE
IN ALUMINUM,

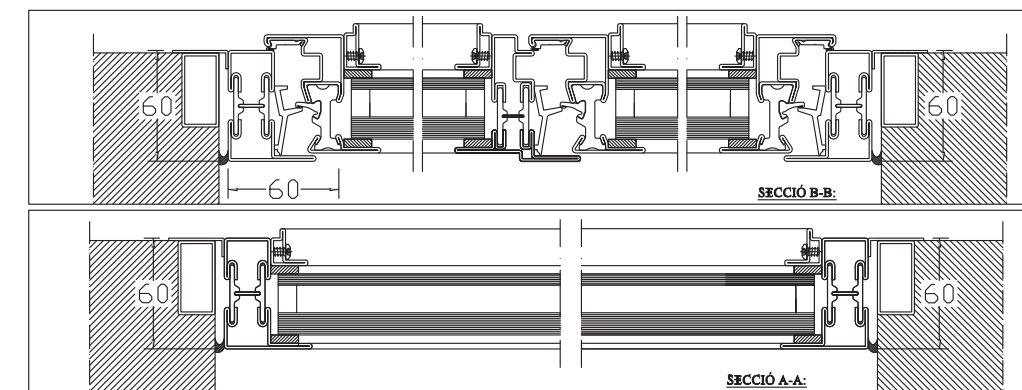



SERRALAVELLA SCHOOL

Ullastrell (Spain)

GARCIA FAURA
ARCHITECTURE
IN ALUMINUM,
STEEL AND GLASS

SERRALAVELLA SCHOOL
Ullastrell (Spain)

Year of completion
2015

Architect
Reverendo-Ginesta associate
architects

Works surface area
Enclosures: 850 m²

Newly built pre-school and primary school, with a main building measuring 4678 m² and the associated exterior spaces (yard and multi-sports areas). The construction set out by the project is dispersed for uses in different structures that occupy the site in a series of steps, over a gradual incline of 14 metres. This means that the visual impact of the volume built is lower. The main entrance on a double-height forms the internal connection of these buildings, while the main yard is located on the first floor and forms the exterior connection. The project and the associated works must fulfil criteria for financial support and rapid execution.



GARCIA FAURA
ARCHITECTURE
IN ALUMINUM,
STEEL AND GLASS

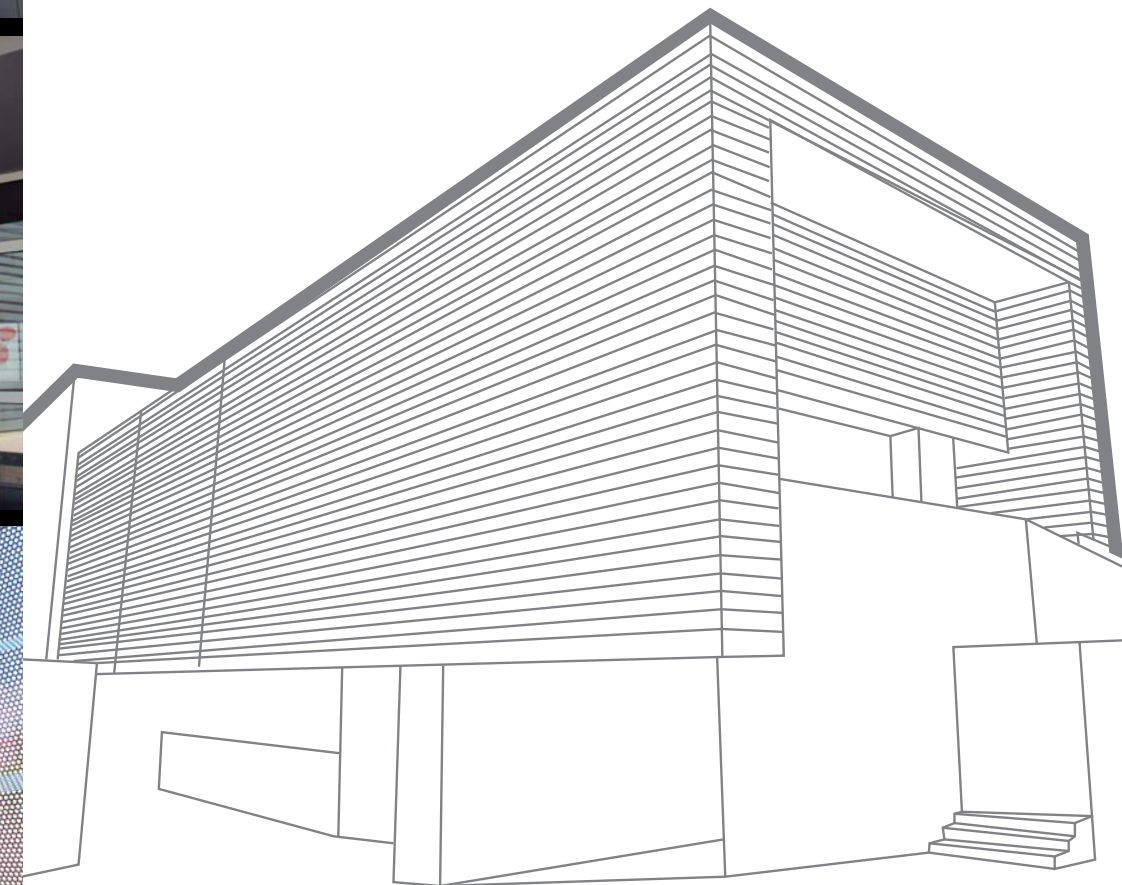



EXTENSION OF TERMINAL D IN BARCELONA PORT

Barcelona (Spain)

GARCIA FAURA
ARCHITECTURE
IN ALUMINUM,
STEEL AND GLASS

EXTENSION OF TERMINAL D IN BARCELONA PORT

Barcelona (Spain)



Year of completion

2014

Architect

Luigi Vicini and Andrea Piazza

Works surface area

Composite panel: 2000 m²

Curtain wall: 100 m²

Skylights: 90 m²

New Cruise Terminal building at Barcelona Port, managed by the Grupo Carnival. As a result of this expansion, the facility gains 1300 square metres of service area and a new high-level connection gangway for cruise liners. This was the first phase of an extension that seeks to convert this services platform of Barcelona Port into a modern facility with multiple services aimed at people on cruises and with the aim of reaching 200 stopovers and 400,000 annual passengers.

GARCIA FAURA fabricated and installed more than 2000 square metres of composite panel in this work; in wall cladding and in shelters and walkways. The facade cladding system was particularly complex and required installation standards that fall within the scope of few industrialists. One of the main characteristics of this panel are its fireproof finish and its high resistance to salt water corrosion, on account of being so close to the sea. The ventilated facade cladding system obtained the European Technical Approval (ETA) which guarantees the construction materials, systems and non-traditional procedures used in public building and works. This certificate verifies the design of the product installation, complying with the strict anchoring procedure and level of omegas required. In addition, **GARCIA FAURA** also built 100 square metres of a curtain wall and 90 square metres of skylights to complete the building's appearance.

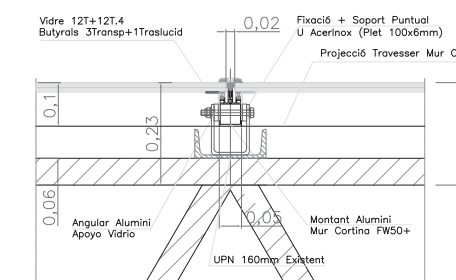
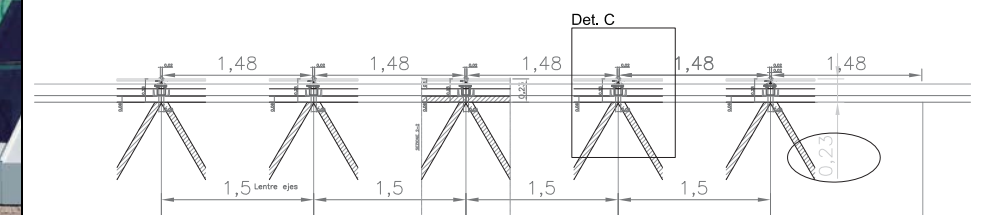

GARCIA FAURA
ARCHITECTURE
IN ALUMINUM,
STEEL AND GLASS



99 BUSINESS CENTRE

Bogotá (Colombia)

GARCIA FAURA
ARCHITECTURE
IN ALUMINUM,
STEEL AND GLASS

99 BUSINESS CENTRE
Bogotá (Colombia)



Year of completion
2015

Architect
CURE Mddg

Works surface area
Glass facade: 1330 m²
Enclosures: 142 m²

The 99 Business Centre is a modern and functional business with outstanding design, quality and safety features. It is notable for its avant-garde architecture, giving rise to comfortable work spaces, with multiple services aimed at companies. The project highlights the ventilation, natural light and acoustic control aspects, committing to high quality and design standards. A building measuring 6800 square metres distributed across 5 storeys in the centre of Bogotá, at the junction of Carrera 13 and Calle 99.

GARCIA FAURA fabricated and installed more than 1300 square metres of curtain wall with a horizontal aileron-type cover. Profiles developed especially by our Drawing Office and extruded expressly for this project. The wall was completed with specific opening points with projecting windows and doors, facilitating the natural ventilation of the building. Most notable of the works performed are the interior windows and doors in the common areas and the coloured glass panes with solar control, which help to reduce the effects of the high exterior sun radiation.



GARCIA FAURA
ARCHITECTURE
IN ALUMINUM,
STEEL AND GLASS



SERVICES BUILDING GUINARDÓ

Barcelona (Spain)

GARCIA FAURA
ARCHITECTURE
IN ALUMINUM,
STEEL AND GLASS

SERVICES BUILDING GUINARDÓ
Barcelona (Spain)



Year of completion
2015

Architect
Bayona Valero architects & Can-
tallops Vicente architects

Works surface area
Enclosures: 274 m²
Glass bannister: 185 ml

The renovation of the old Guinardó Market entailed reorganising the surrounding area, from an urban development perspective, but also in terms of uses and services. In this regard, the new island of buildings resulting from the reorganisation led to the construction and setting up of a new health centre, a youth centre, a residence for the elderly, a crèche and a car park with 150 spaces. As such, this district now boasts a new social, commercial and citizen hub.

In this project GARCIA FAURA was responsible for the manufacturing and installation of the aluminium windows and doors for the geriatric residence, the health centre and the youth centre of the Guinardó district. Considering the size of some of these windows and doors, an individual study of each of them was performed in order to find tailor-made solutions to reinforce posts or crossbeams, according to the surface area and the wind load of each unit.



GARCIA FAURA
ARCHITECTURE
IN ALUMINUM,
STEEL AND GLASS

SECCIÓ HORIZONTAL B-B:

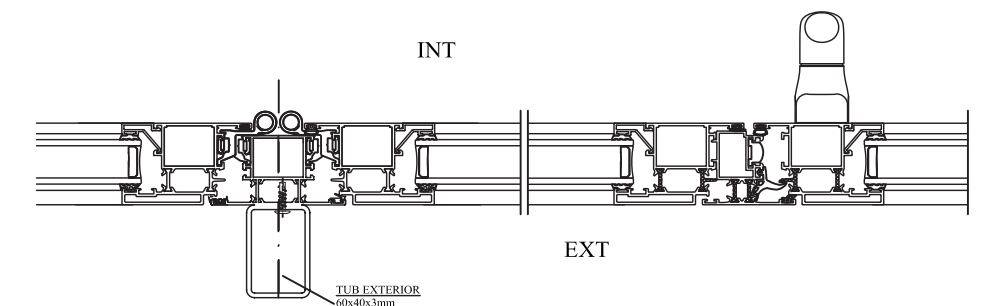



GUINARDÓ MARKET

Barcelona (Spain)

GARCIA FAURA
ARCHITECTURE
IN ALUMINUM,
STEEL AND GLASS

GUINARDÓ MARKET
Barcelona (Spain)

Year of completion
2015

Architect
Bayona Valero architects & Can-
tallops Vicente architects

Works surface area
Enclosures: 1075 m²
Aluminium veneer cladding: 682
m²

The new Guinardó Market is part of a large island of buildings that represents a new meeting and services area for residents in this Barcelona district. The new market has maintained part of the emblematic tower in the old building, which helps to visually identify the place. The renovation has also adapted the commercial offer, in such a way that the sales space is shared between fifteen stands taking up a surface area of 2000 square metres, and a self-service area managed by the supermarket chain Carrefour. The main entrance has been improved by the new open square between the market and Pasaje de Llívia, which leads directly on to the floor where the stands of non-food products are located.

The majority of the works carried out by **GARCIA FAURA** in this project consisted in manufacturing and installing more than 1000 m² of aluminium windows and doors with thermal break. The windows and doors have an anodised black matt finish, which is a characteristic feature of the project. The double glazed windows have a selective layer to reduce the effect of the sun. The windows and doors in this project had to be studied individually, since each of them required a supportive solution of posts or crossbeams, according to the surfaces and wind load.

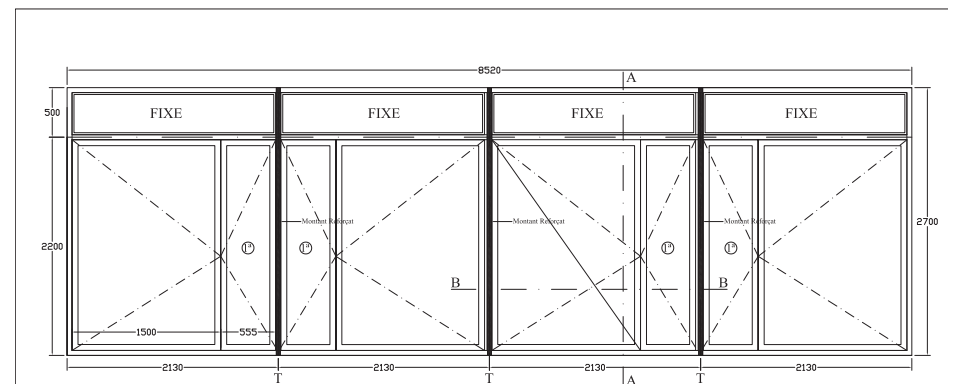
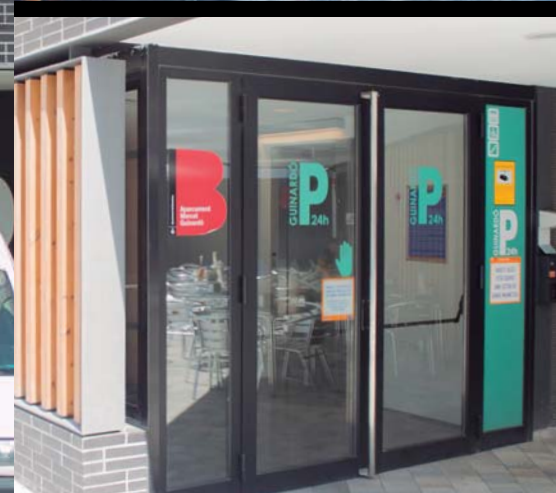

GARCIA FAURA
ARCHITECTURE
IN ALUMINUM,
STEEL AND GLASS



L'HOSPITALET RONDA FUNERAL HOME

L'Hospitalet de Llobregat (Spain)

GARCIA FAURA
ARCHITECTURE
IN ALUMINUM,
STEEL AND GLASS

L'HOSPITALET RONDA FUNERAL HOME
L'Hospitalet de Llobregat (Spain)



Year of completion
2015

Architect
Ribas & Ribas

Works surface area
Enclosures: 810 m²
Curtain wall: 115 m²

The new funeral home in the city of Hospitalet de Llobregat is notable for its curved facade and views over the city and the region's low valley. The building has approximately 7000 square metres, distributed over two underground floors, a ground floor and a first and second floor above ground level. The installations include six visitation rooms with large terraces located between the first and second floor, which are designed to connect the indoor and outdoor spaces. The building also contains a ceremonial room that can host 230 people, a public attention and services area, and an underground car park with 60 spaces.

GARCIA FAURA performed the aluminium and glass joinery, with all the window and door solutions, and a small polygonal curtain wall on an existing steel structure with glazing via an aileron vertical cover. In addition, the work also included an auxiliary galvanised steel structure with an insulation panel, as well as the set of skylights, railings and interior screens.



GARCIA FAURA
ARCHITECTURE
IN ALUMINUM,
STEEL AND GLASS

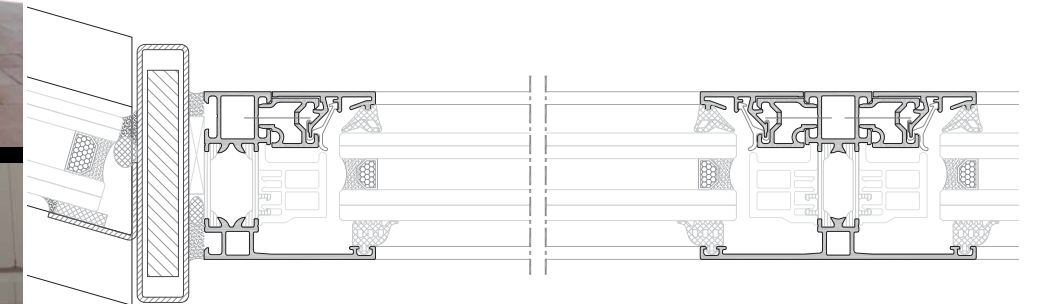



PODIUM SPORTS COMPLEX

Viladecans (Spain)

GARCIA FAURA
ARCHITECTURE
IN ALUMINUM,
STEEL AND GLASS

PODIUM SPORTS COMPLEX
Viladecans (Spain)

PODIUM
VILADECANS ESPORTS
Joan Masgrau

Year of completion
2015

Architect
Brullet - De Luna

Works surface area
Enclosures: 2000 m²
Curtain wall: 500 m²

The Joan Masgrau Podium sports complex in Viladecans comprises three large areas: a sports centre, a hall for directed activities and the water zone, with an indoor and outdoor swimming pool. It forms part of the Torre Roja park, and is open for individual sports practice and that of the city's different clubs and entities. In fact, one of the premises of the project, was the maximum versatility of the different spaces, as well as the energy-saving strategy. In this project the Brullet - De Luna studio created a design that helps to obtain as much natural light as possible through skylights, temperature control promoted by the layout of intermediate spaces and the control of sun radiation through brise-soleil structures.

GARCIA FAURA contributed towards this energy-saving with the manufacturing and installation of its products. We created large fixed modules and two large curtain walls for the swimming pool area, which allow the maximum amount of light to enter the interior of the building, while creating a visual sense of continuity between rooms. The works also allowed for the incorporation of more than 2000 square metres of aluminium windows and doors with profiles with a thermal break, which increase the user's sense of interior comfort by allowing greater thermal insulation between the interior and the exterior.



Sección sobre pilar de madera.

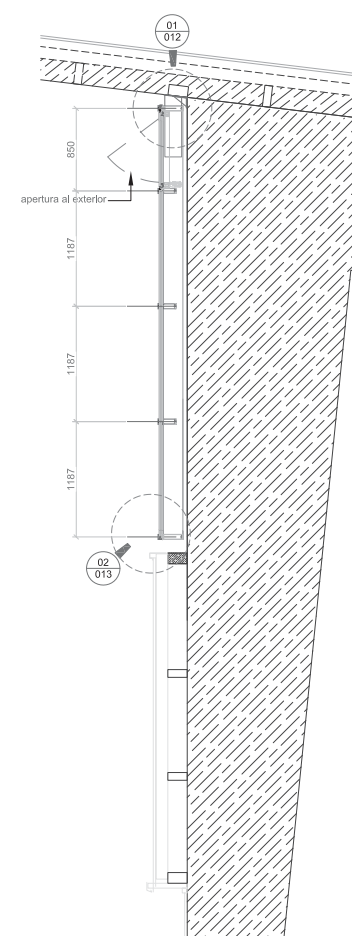

Sección entre pilares de madera.

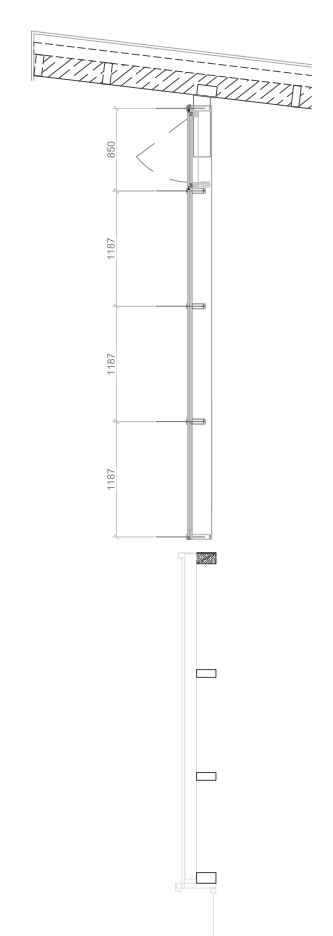

GARCIA FAURA
ARCHITECTURE
IN ALUMINUM,
STEEL AND GLASS



LES MASIES DE MOLLET RESIDENCE

Mollet del Vallès (Spain)

GARCIA FAURA
ARCHITECTURE
IN ALUMINUM,
STEEL AND GLASS

LES MASIES DE MOLLET RESIDENCE
Mollet del Vallès (Spain)



Year of completion
2014

Architect
Guillermo Muñoz
GRAM Arquitectura

Works surface area
Enclosures: 450 m²
Aluminium veneer cladding and
finishing: 600 m²

A new residential and day centre building for the elderly, designed as a modern and highly functional ensemble, to ensure the wellbeing of its users. The residence has an accessible design and is equipped with the latest technology. It is structured into several cohabitation units, all exterior rooms and has made maximum use of the natural light. The building can host 150 residents and 40 in the day centre. All the entrances are fully accessible and mobility in the centre is facilitated. The building is part of a construction block which, with independent entrances, also contains a shopping centre.

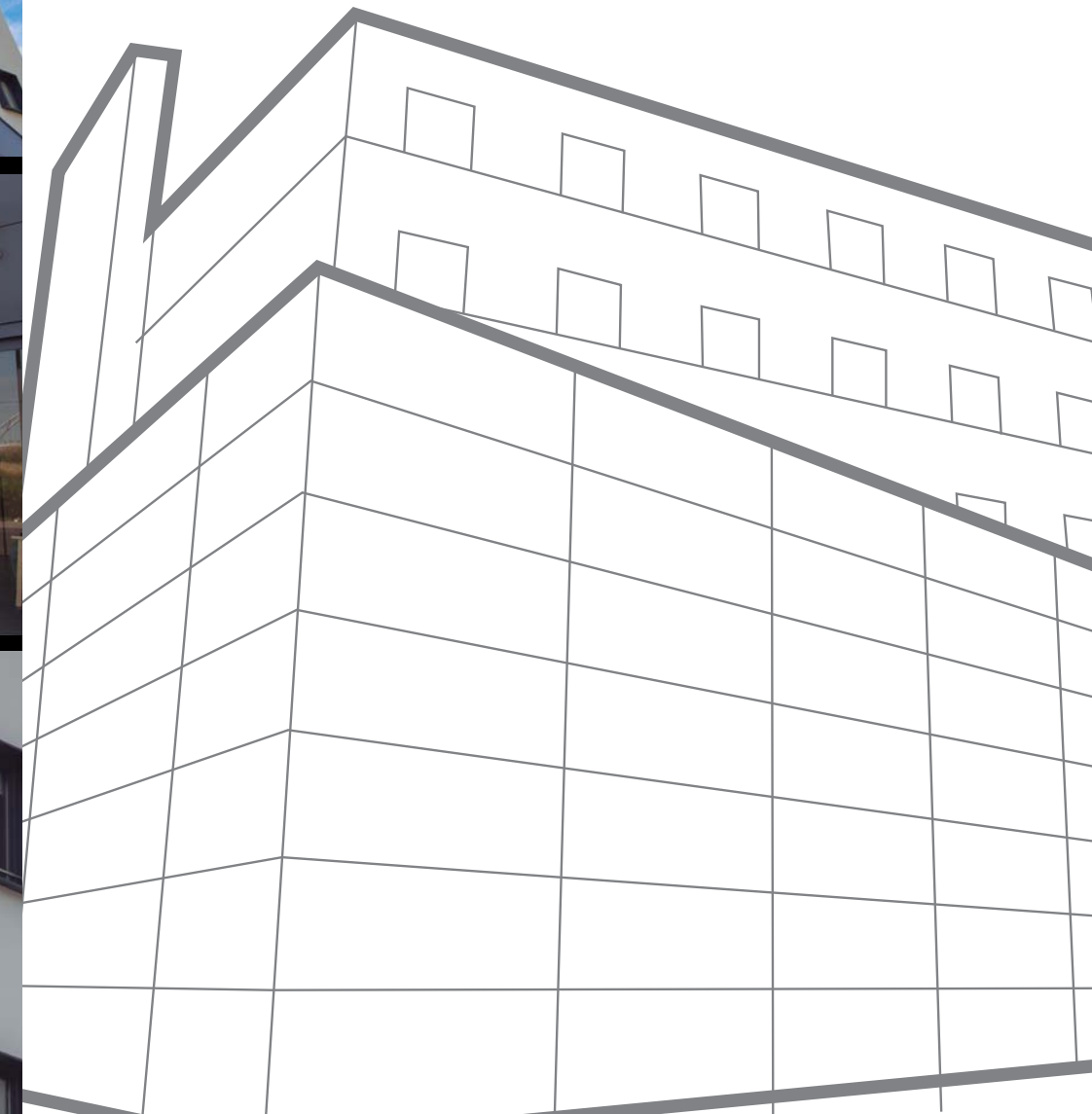
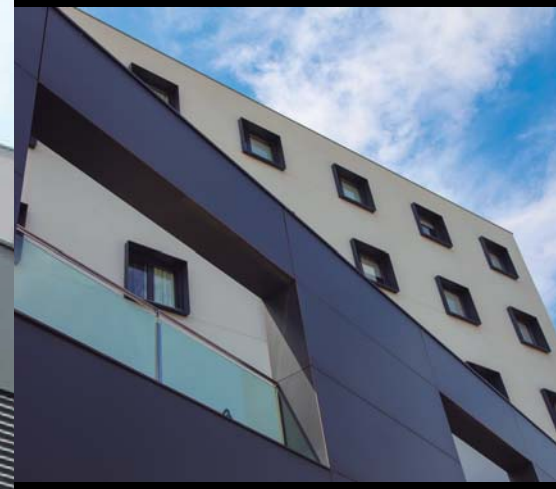

GARCIA FAURA
ARCHITECTURE
IN ALUMINUM,
STEEL AND GLASS



CONSTITUCIÓN MARKET AND SERVICES BUILDING

Viladecans (Spain)

GARCIA FAURA
ARCHITECTURE
IN ALUMINUM,
STEEL AND GLASS

CONSTITUCIÓN MARKET AND SERVICES BUILDING
Viladecans (Spain)



Year of completion
2014

Architect
Jordi Ros & Jordi Sutrias

Works surface area
Enclosures: 450 m²

Project to transform the Plaza de la Constitució of Vildecans, including the building of a new town market, a services building for entities and citizens, and a block of apartments, as well as the setting up of green areas for public use. The centre of this new space is the market building, with 14 indoor stands and 6 outdoor stands. The project also includes the installation of a new supermarket from the Mercadona chain. All of this turns the square into the new economic core of the Montserrat district and helps to extend the commercial cluster making up the exterior pedestrian area.

GARCIA FAURA'S action focused on the manufacturing and installation of all the aluminium window and door solutions that make up the services building and the apartment block, with a combination of casement and sliding doors and windows, according to the use. All of them have a thermal break, to improve the buildings' services and the wellbeing of the new inhabitants. In the commercial building, we worked on the exterior glass parameters, as well as any entrances with automatic doors.

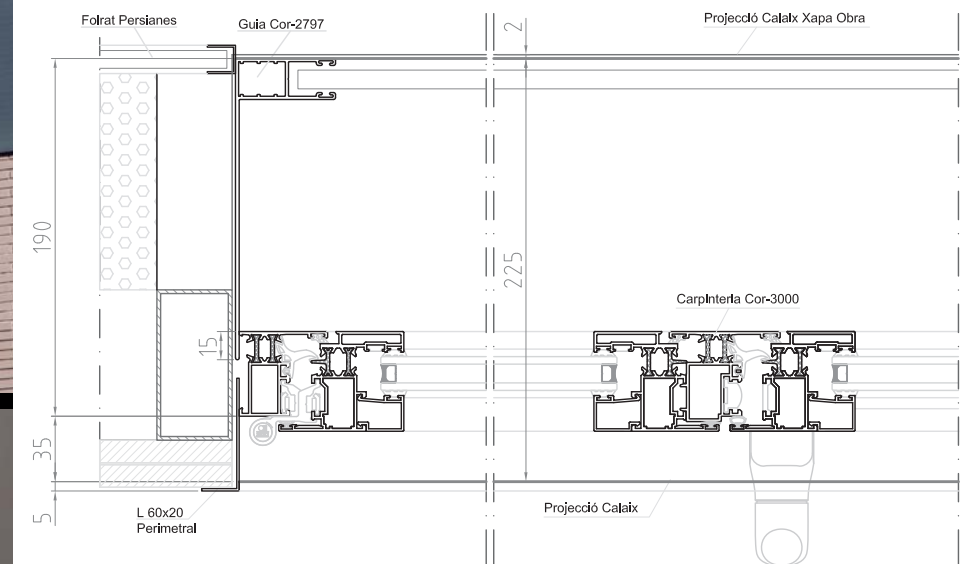

GARCIA FAURA
ARCHITECTURE
IN ALUMINUM,
STEEL AND GLASS



SANT JUST HOUSING DEVELOPMENT

Sant Just Desvern (Spain)

GARCIA FAURA
ARCHITECTURE
IN ALUMINUM,
STEEL AND GLASS

SANT JUST HOUSING DEVELOPMENT
Sant Just Desvern (Spain)

Year of completion
2015

Works surface area
Enclosures: 1390 m²

Housing development built on Calle de las Cadenas, in Sant Just Desvern. This comprises 96 apartments in two blocks, each comprising four floors. The development includes communal areas such as a swimming pool, children's playground and exterior private area.

In this development **GARCIA FAURA** was responsible for the manufacturing and installation of all the aluminium and glass joinery. They were fabricated using profile systems with thermal break and glass of different compositions, according to the soundproofing needs of each space. In total, almost 1400 square metres of doors and windows were manufactured and installed.

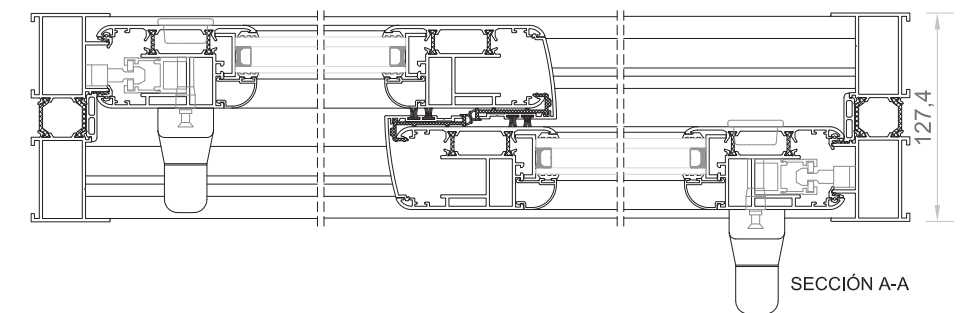

GARCIA FAURA
ARCHITECTURE
IN ALUMINUM,
STEEL AND GLASS



RENOVATION OF NINOT MARKET

Barcelona (Spain)

GARCIA FAURA
ARCHITECTURE
IN ALUMINUM,
STEEL AND GLASS

RENOVATION OF NINOT MARKET
Barcelona (Spain)



Year of completion
2015

Architect
MAP Arquitectes
MUR GARGANTÉ Arquitectes

Works surface area
Curtain wall: 1680 m²
Stainless panels Facade: 710 m²
Stall enclosures: 250 m²



After several years of works, the city of Barcelona has renovated one of its most iconic municipal markets. The project, managed by the architect Josep Lluís Mateo, entailed modernising the installations and reorganising the commercial system. The roof was renovated and new cladding was applied to the exterior facade. This new exterior appearance makes the market more visible and gives it a more modern image. In addition, it helps to filter the sunlight coming into the inside of the market, and prevents direct solar radiation on the products at the stands.

GARCIA FAURA was responsible for renovating several sections. On the one hand, the entire exterior appearance of the market, with the manufacturing and installation of more than 2000 square metres of steel curtain wall and transforming cladding using folded and perforated stainless steel veneers. The company was also responsible for creating the window and door solutions of 18 outdoor stands built into the market structure, and made of panels of galvanised steel and swing up doors which, once open, serve as a shelter for the stand. Inside the market, **GARCIA FAURA** installed interior windows and doors composed of laminated and toughened transparent glass, as well as several metal works in the entrance zones.

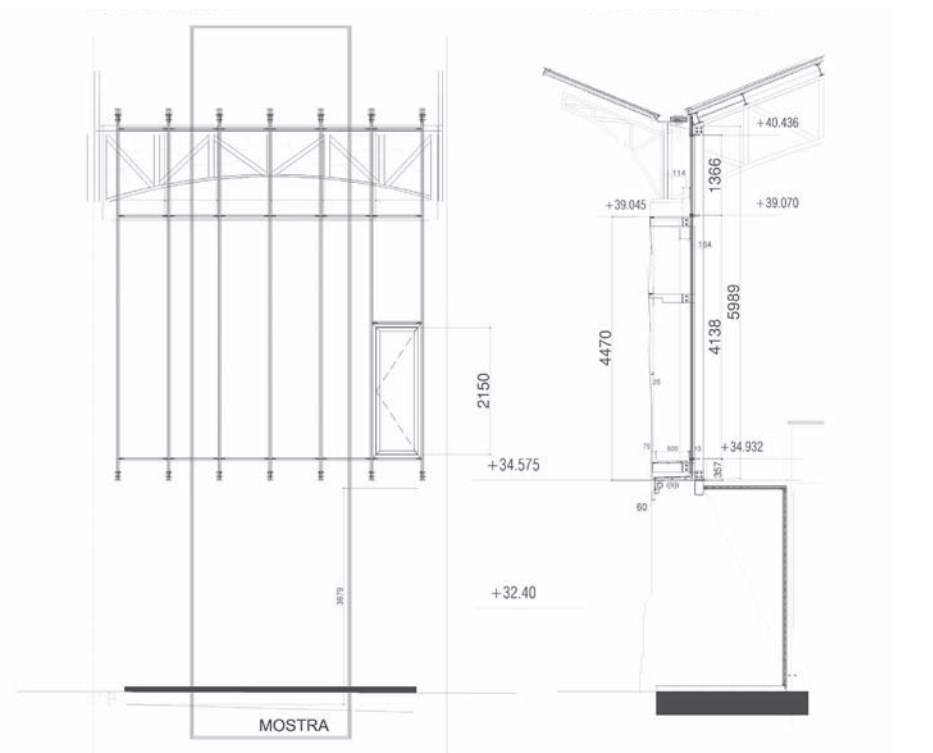

GARCIA FAURA
ARCHITECTURE
IN ALUMINUM,
STEEL AND GLASS



YURBBAN TRAFALGAR HOTEL

Barcelona (Spain)

GARCIA FAURA
ARCHITECTURE
IN ALUMINUM,
STEEL AND GLASS

YURBBAN TRAFALGAR HOTEL
Barcelona (Spain)



Year of completion
2014

Architect
Blanch + Conca Arquitectura

Works surface area
Enclosures: 80 units
Curtain wall: 50 m²

New cosmopolitan and urban designer hotel, located in the centre of Barcelona, in the former head office of the textile company Marxan. The building was entirely renovated to adapt to its new use. The building's modern structure, measuring more than 3000 square metres, worked in our favour, and the renovated facade has become a distinctive feature of the new hotel. It has more than 60 rooms and restaurant services, and it has become the first hotel building with these characteristics in the Smart Rooms chain in the centre of Barcelona.

GARCIA FAURA performed the aluminium, glass and steel works to renovate the old building where the hotel is located and give it the avant-garde image that the brand wants to present to its customers. The installation's window and door solutions were fitted, as well as a curtain wall that allows a considerable amount of natural light to enter, and connects the inside and the outside of the building.

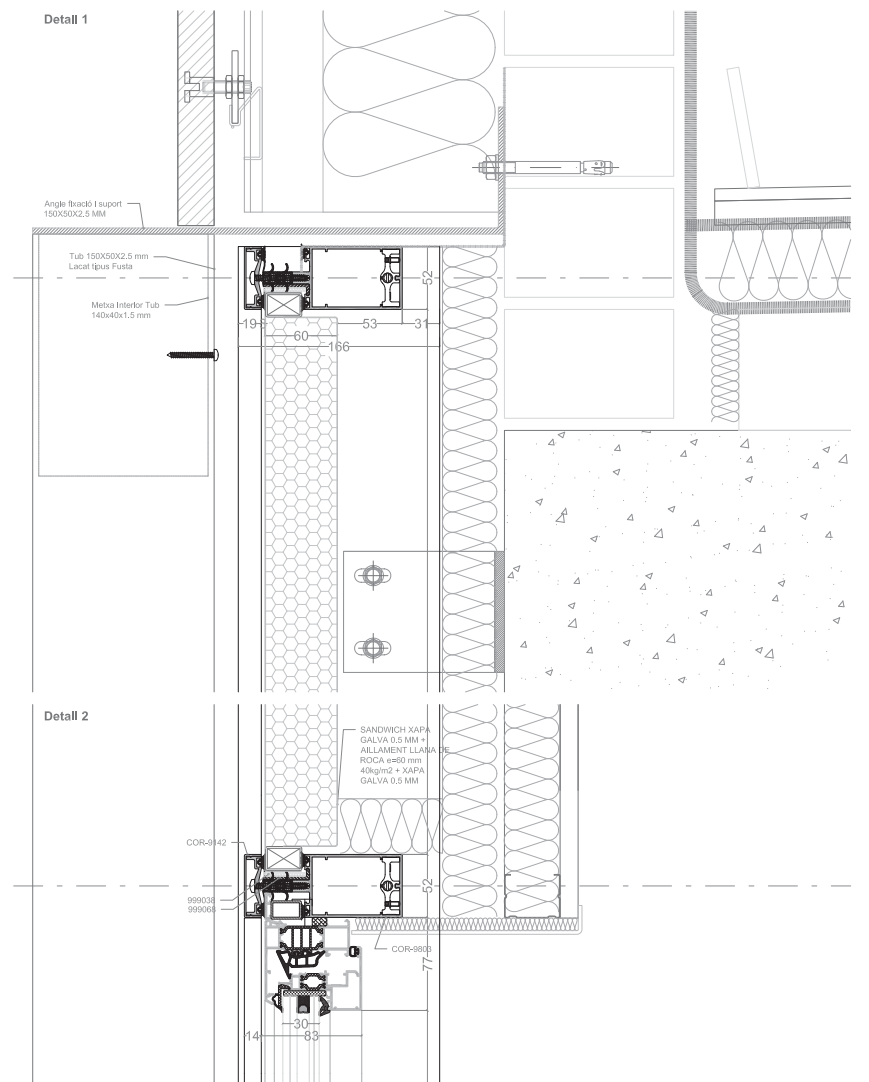

GARCIA FAURA
ARCHITECTURE
IN ALUMINUM,
STEEL AND GLASS



RENOVATION OF OFFICE BUILDING BALMES

Barcelona (Spain)

GARCIA FAURA
ARCHITECTURE
IN ALUMINUM,
STEEL AND GLASS

RENOVATION OF OFFICE BUILDING BALMES

Barcelona (Spain)

Year of completion

2015

Architect

Eduard Gascón and Jordi Roig /
Xavier Ferrés

Works surface area

Enclosures: 325 m²
Curtain wall: 340 m²
Aluminium sheets: 140 m²
Aluminium veneer cladding: 350 m²

Comprehensive renovation of a 1967 building to adapt it to the requirements of current office buildings. The project entailed replacing the facades with new windows and doors that interpret the current notably vertical appearance of this sector of the Eixample district. The new main facade uses glass as the showcased material, in a smooth and subtle design, with a notably technological appearance, laid out in vertical strips that show the thickness and complexity of window and door solutions in which the spaces are defined by glass platforms that stand out on the background of an extruded wall built using a lattice of ceramic tubes.

GARCIA FAURA made the curtain wall on the main facade, combining aluminium profiles on the ground floor, recesses and projections with occasional windows, fixed glazing and aluminium veneer cladding on the office floors. It is combined with an interior facade of large aluminium windows and complex cladding, creating cantilevers and rods on the main facade. The works were completed with glass bannisters, skylights and other elements included in this great renovation, analysed in detail from the structural calculus perspective.

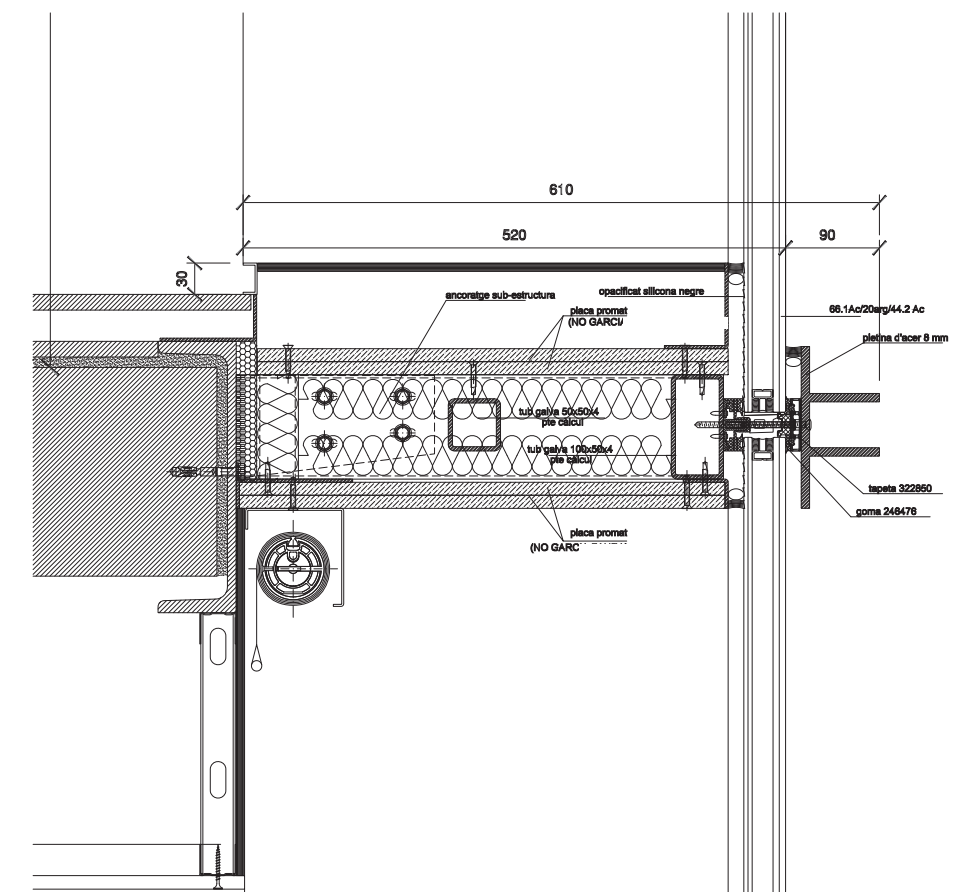

GARCIA FAURA
ARCHITECTURE
IN ALUMINUM,
STEEL AND GLASS



VERGÓS HOUSING DEVELOPMENT

Barcelona (Spain)

GARCIA FAURA
ARCHITECTURE
IN ALUMINUM,
STEEL AND GLASS

VERGÓS HOUSING DEVELOPMENT
Barcelona (Spain)



Year of completion
2015

Works surface area
Enclosures: 960 m²
Skylight: 70 m²

Upscale housing development in the upper district of the city of Barcelona. The apartments boast top quality finishes, and the building has excellent communal spaces, such as a heated swimming pool, a gym, a children's play area and a garden.

In this development **GARCIA FAURA** was responsible for the manufacturing and installation of all the aluminium and glass joinery. They were fabricated using profile systems with a thermal break and different composition glass to guarantee efficient thermal and acoustic insulation. The works were completed with the installation of solar protection and an interior skylight measuring 70 square metres.

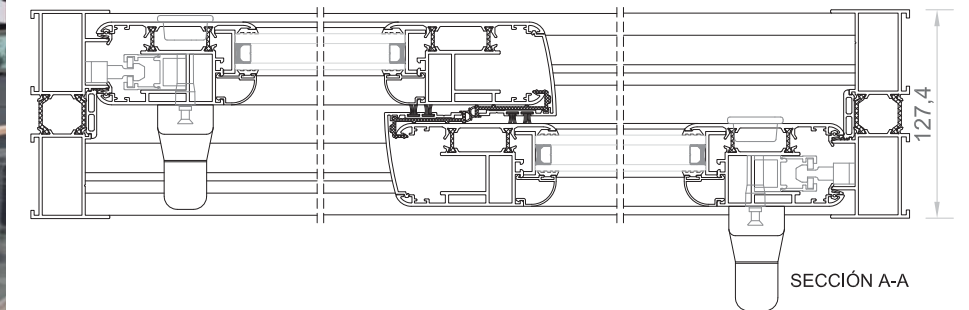
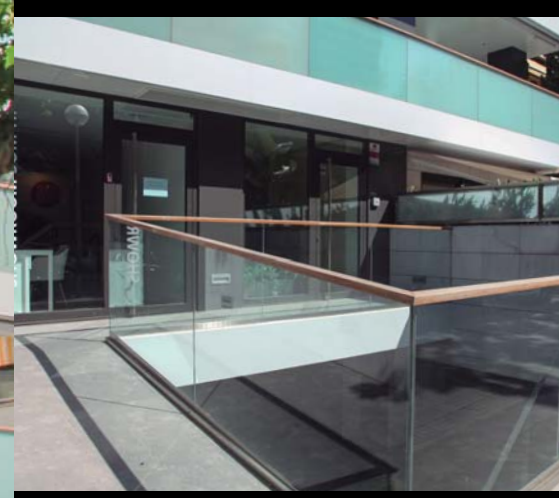

GARCIA FAURA
ARCHITECTURE
IN ALUMINUM,
STEEL AND GLASS



SERVICE UNIT SAGRADA FAMILIA CHURCH

Barcelona (Spain)

GARCIA FAURA
ARCHITECTURE
IN ALUMINUM,
STEEL AND GLASS

SERVICE UNIT
SAGRADA FAMILIA CHURCH
Barcelona (Spain)

Year of completion
2013

Architect
2BMFG Arquitectes

Works surface area
Curtain wall: 168 m²
Facade cladding: 623 m²
Enclosures: 44 m²

GARCIA FAURA'S first works in the historical monument of the basilica of the Sagrada Familia, declared a UNESCO World Heritage Site. The works included building the services area, including the shop, and cloakroom and toilet facilities for staff. A building composed of two prisms that fit together at the corner of the church, joined to each other by an interior emergency staircase. The goal was to identify and solve the new necessities that had appeared during the development of the church construction works.

GARCIA FAURA fabricated and installed the glass facade, windows and doors and exterior cladding. The most notable element is the 168-metre long curtain wall, built in a non-linear fashion, giving the structure a truly unique appearance. This facade is complemented by more than 600 square metres of sandwich panel cladding and aluminium windows and doors with thermal break. These works were carried out painstakingly and entailed many logistic difficulties, on account of combining the works with the constant flow of tourists to the monument, which every year attracts more than 3 million visitors.



MUR MC1 (Vist Exterior)

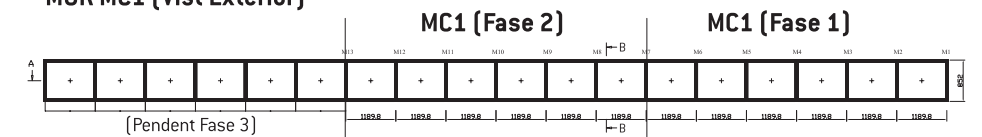

RELACIÓ DE MONTANTS Ref. FM156 (80mm) ANOD. PLATA MATE. Vist Exterior

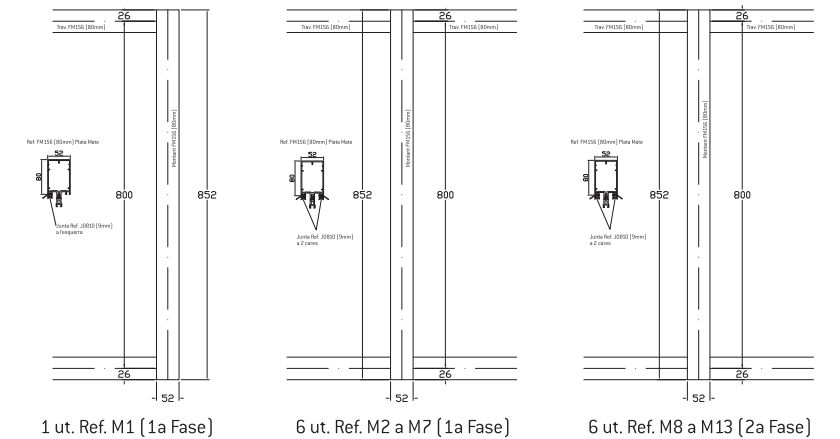

GARCIA FAURA
ARCHITECTURE
IN ALUMINUM,
STEEL AND GLASS



RENOVATION OF THE AIGÜES DE BARCELONA BUILDING

Barcelona (Spain)

GARCIA FAURA
ARCHITECTURE
IN ALUMINUM,
STEEL AND GLASS

RENOVATION OF THE AIGÜES DE BARCELONA BUILDING

Barcelona (Spain)



Year of completion

2014

Architect

Ferrés Arquitectes

Works surface area

Aluminium railings: 290 units

Exterior mouldings: 2780 ml

Sun blinds: 215 units

Renovation of the facade of this building designed by Leopoldo Rodés and converted in 2014 into the new corporate headquarters of Aigües de Barcelona. The building is designed in the shape of a glass cube, in an endeavour to make the most of the natural light on all the facades. It measures more than 13,000 square metres and is fitted with the most modern installations and services to manage the more than 100 installations Aigües de Barcelona has all across the territory.

The renovation sought to intervene in the facade to improve the thermal comfort of the building. The highly technically complex project, directed by Xavier Ferrés, consisted in installing corrugated metal mouldings between the facade glass, as well as making perforations in the existing hoods. With these works, the ventilation of the building was improved, and in periods of high temperatures, a general drop in the interior temperature was obtained compared to the exterior temperature.

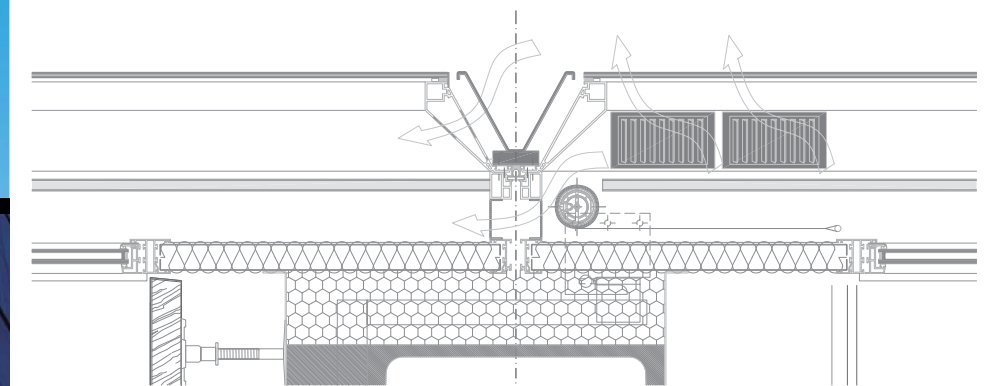
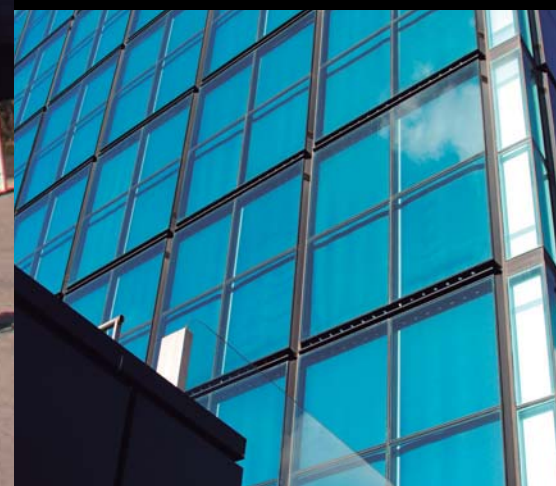

GARCIA FAURA
ARCHITECTURE
IN ALUMINUM,
STEEL AND GLASS



HOTEL SB PLAÇA EUROPA

L'Hospitalet de Llobregat (Spain)

GARCIA FAURA
ARCHITECTURE
IN ALUMINUM,
STEEL AND GLASS

HOTEL SB PLAÇA EUROPA
L'Hospitalet de Llobregat (Spain)



Year of completion
2013

Architect
BCA Blanch + Conca Arquitectura

Works surface area
Enclosures: 1723 m²
Curtain wall: 262 m²



GARCIA FAURA
ARCHITECTURE
IN ALUMINUM,
STEEL AND GLASS

The new Hotel SB Plaça Europa is a 4-star hotel establishment, with avant-garde decoration, where noble materials and Mediterranean colours prevail. A cosmopolitan and contemporary establishment set to become a leading hotel in one of the country's thriving economic districts. Among the establishment's most notable services are the restaurant, the cafeteria with a garden terrace, the panoramic terrace with swimming pool, and the solarium and gym.

GARCIA FAURA developed the architecture project in aluminium and glass, being in charge of the windows and doors and the glass facade. As regards the latter, a curtain wall measuring 250 square metres, with horizontal and vertical covers, was fabricated and installed. All of the windows and doors, more than 330 units, have a thermal break and hidden sash aluminium profiles. A manufacturing system that combines outstanding technical features with impeccable aesthetics. They have a simple line with a small interior moulding which gives a slender appearance, creating a symbolic shadow effect. The windows are finished with an upper aluminium veneer.

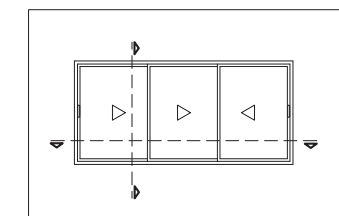

Alçat Corredissa 3F-3V

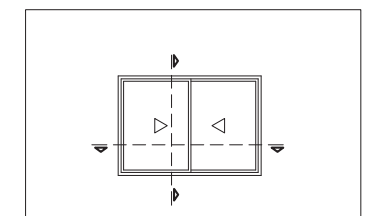

Alçat Corredissa 2F-2V

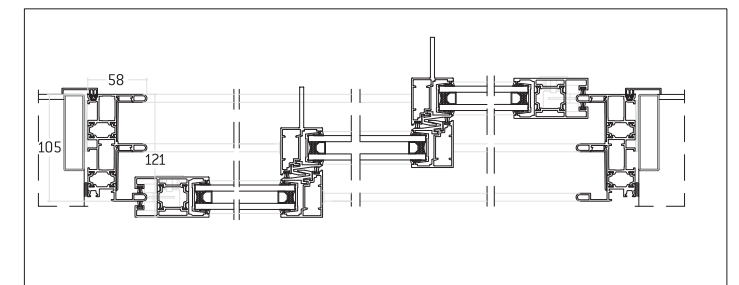

Secció Horitzontal (E 1:4): Corredissa 3F-3V

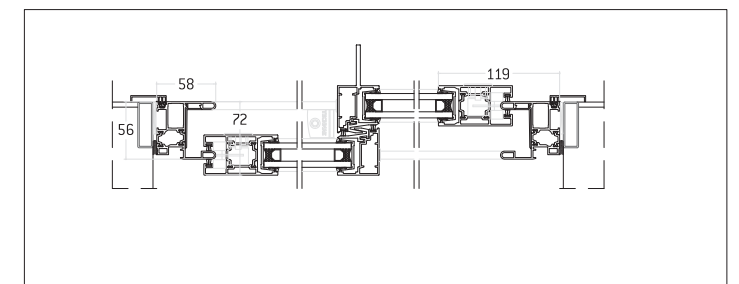

Secció Horitzontal (E 1:4): Corredissa 2F-2V



GRIMALDI TERMINAL

Barcelona (Spain)

GARCIA FAURA
ARCHITECTURE
IN ALUMINUM,
STEEL AND GLASS

GRIMALDI TERMINAL
Barcelona (Spain)



Year of completion
2013

Architect
Yannic Levêque

Works surface area
Curtain wall: 897 m²
Enclosures: 386 m²

New passenger terminal in Barcelona Port, for one of the largest shipping companies in the world. Grimaldi Group has invested more than 20 million Euro in its new terminal on the Costa pier. A new infrastructure, designed by Yannic Levêque, with room for 1800 embarking and disembarking passengers. It includes a three-storey building with a surface area of 3750 square metres, a paved esplanade and a platform with three connection gangways between the terminal and the docks.

In this work, **GARCIA FAURA** fabricated and installed a 9-metre-high curtain wall without intermediate support in the staircases. The glass in this curtain wall is mechanically fixed to the structure. The profile used in the work was specially extruded for the project, to facilitate the technical and aesthetic needs of the customer. The project is completed with the aluminium doors, latticework and interior glass screens that make up the passenger rooms.



Secció Vertical
(E 1:20)

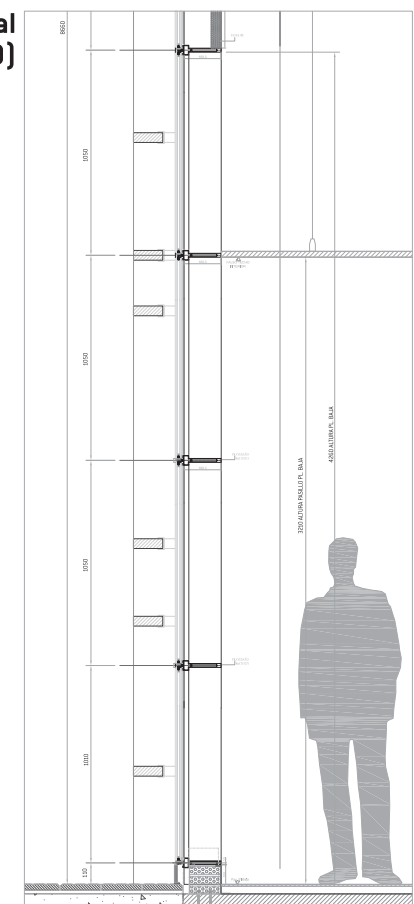

GARCIA FAURA
ARCHITECTURE
IN ALUMINUM,
STEEL AND GLASS



EXTENSION OF SANT JOAN DE DÉU HOSPITAL

Manresa (Spain)

GARCIA FAURA
ARCHITECTURE
IN ALUMINUM,
STEEL AND GLASS

EXTENSION OF SANT JOAN DE DÉU HOSPITAL
Manresa (Spain)



Year of completion
2014

Architects
Jaume Espinal
Joan Ribera
Estudi PSP Arquitectura

Works surface area
Enclosures: 2395 m²
Veneer cladding: 1309 m²
Interior glazing: 912 m²



GARCIA FAURA
ARCHITECTURE
IN ALUMINUM,
STEEL AND GLASS

Extension of the former Manresa Hospital to convert it into the leading health centre in Central Catalonia. The work, performed in different phases, extended the hospital by 40,000 square metres, providing it with new healthcare and hospitalisation blocks, external offices, a surgical area and a new radiotherapy bunker. These extension works had to be combined with the maintenance of the healthcare activity in the operational part of the building, and ended up turning this Althaia Foundation centre into a first-rate healthcare model.

GARCIA FAURA is in charge of the 566 window and door units of the second phase of extending the hospital, and uses a manufacturing system that includes a thermal break and high levels of technical and acoustic functionality. In total, almost 2500 square metres in addition to the facade works consisting of the decorative corrugated aluminium cladding in saw-tooth arrangement. A material that brings a unique touch to the interior patios in the new hospital centre.

SECCIÓNS VERTICALS

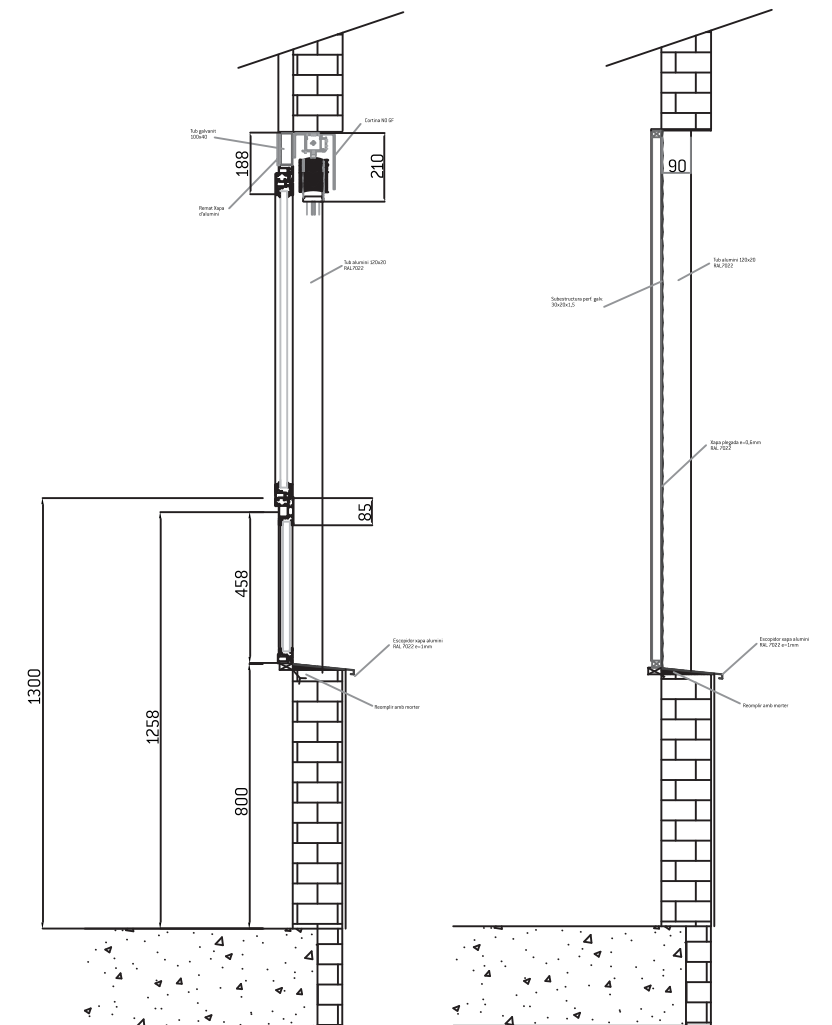



FC BARCELONA SOCIAL AREA

Barcelona (Spain)

GARCIA FAURA
ARCHITECTURE
IN ALUMINUM,
STEEL AND GLASS

FC BARCELONA SOCIAL AREA
Barcelona (Spain)



Year of completion
2013

Architect
Blanch + Conca Arquitectura

Works surface area
Enclosures: 410 m²
Sandwich panel: 950 m²
Aluminium veneer cladding: 1400 m²



New headquarters of the FC Barcelona Social Area, which is based on the existing structure of the former building, known as the Picadero. The space contains the FC Barcelona Member Services Office, the FC Barcelona Supporter Office, the Specialised Supporter Services Office, the Paris Room, a restaurant area, as well as service and warehouse areas. The architectural project is based on an aesthetic and functional double slope, which converts the building into a pleasant space for members, and provides a new more dignified access into the premises of the azulgrana team.

The cladding of the complex and slanted facades, combining different mouldings of different sized microperforated and folded metal veneers, was the main challenge in this work, which **GARCIA FAURA** solved swiftly and efficiently. The installation of these mouldings was a proposal to satisfy the needs of the Project Management, combining it with the installation of other joinery, large fixed panels and entrance doors to the different areas in the building.

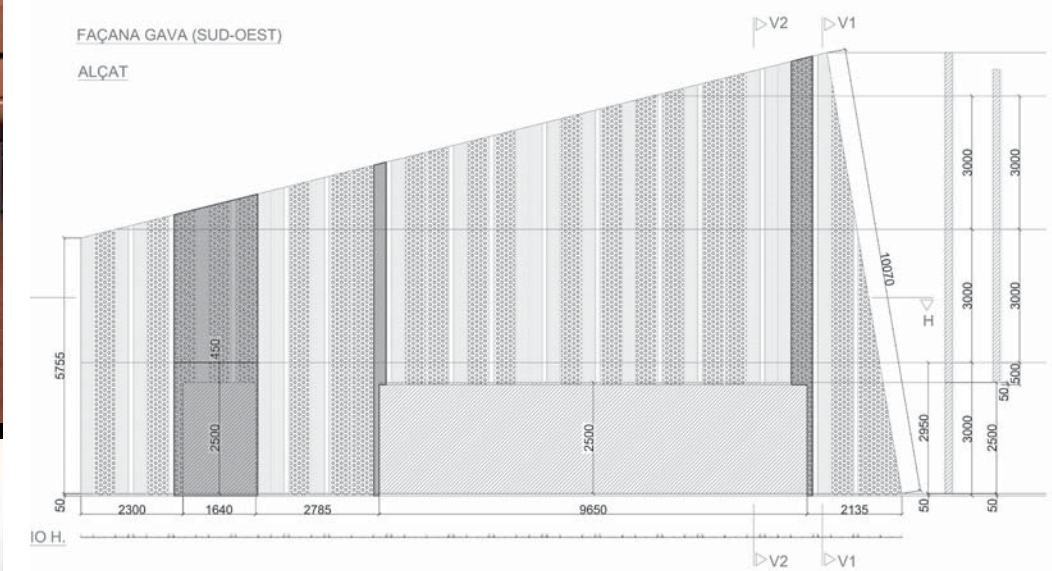

GARCIA FAURA
ARCHITECTURE
IN ALUMINUM,
STEEL AND GLASS



PANAMA ELECTORAL COURT

Ciudad de Panamá (Panamá)

GARCIA FAURA
ARCHITECTURE
IN ALUMINUM,
STEEL AND GLASS

PANAMA ELECTORAL COURT
Ciudad de Panamá (Panamá)



Ending year
2013

Architect
David Tapia y Rafael Watson

Works surface area
Handrails: 1.300 m

The new headquarters of the Electoral Courte consists in three different buildings, set up in an orthogonal way, in a 3,2 hectares patch with 36.500 square meters of built area. The main access is symmetrically distributed along the central building and is bounded by an atrium of four stores. The offices of the Despacho Superior, the Auditorium and the Conference room are located at both sides of the main entrance. The new headquarters reunite more than 1.200 public workers who previously were assigned to over 10 different facilities around the Calidonia region.

GARCIA FAURA is the company in charge of the fabrication and installation of all the handrails of the complex. Those handrails are made from metallic profiles with a dark brown matte finish, complemented with vertical stiffeners and a railing. The metallic structure is covered up by plaster and reinforced cement panels. Once on site, all the panels are given an external treatment in order to improve their durability and meet the aesthetic requirements of the project.



GARCIA FAURA
ARCHITECTURE
IN ALUMINUM,
STEEL AND GLASS



TECHNOLOGICAL CENTER OF MANRESA

Manresa (Spain)

GARCIA FAURA
ARCHITECTURE
IN ALUMINUM,
STEEL AND GLASS

TECHNOLOGICAL CENTER OF MANRESA
Manresa (Spain)



Year of completion
2013

Architect
Eduard Gascón y Jordi Roig

Works surface area
Glass facade: 2.159 m²

Enclosures: 1.370 m²

Composite: 1.760 m²

Déployé mesh: 1932 m²

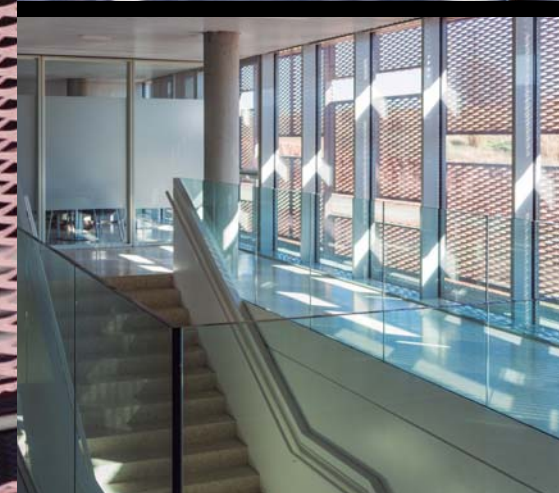
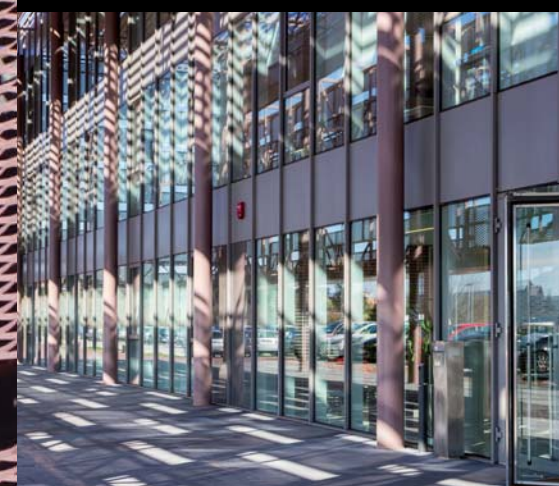

GARCIA FAURA
ARCHITECTURE
IN ALUMINUM,
STEEL AND GLASS

Technology research building perfectly set in the landscape and natural environment. Unobtrusive in appearance, this sheet metal structure blends in with the landscape and is arranged with a series of courtyards that let in natural light while offering a range of different indoor activities and doubling as climate control and energy savings features.

SECCIÓ VERTICAL (1)

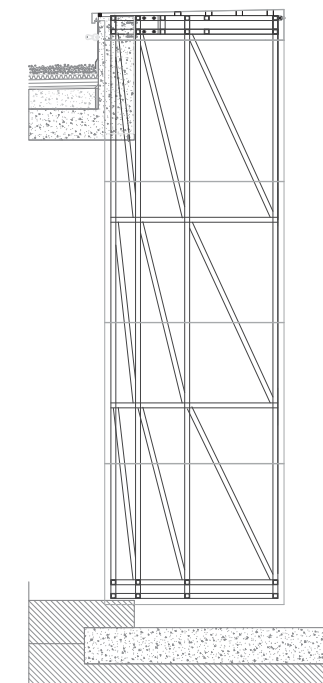

SECCIÓ VERTICAL (2)

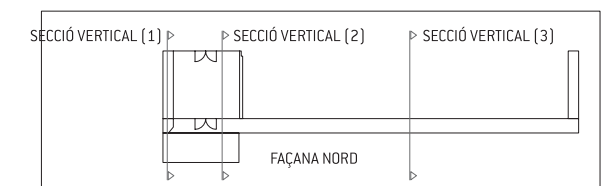
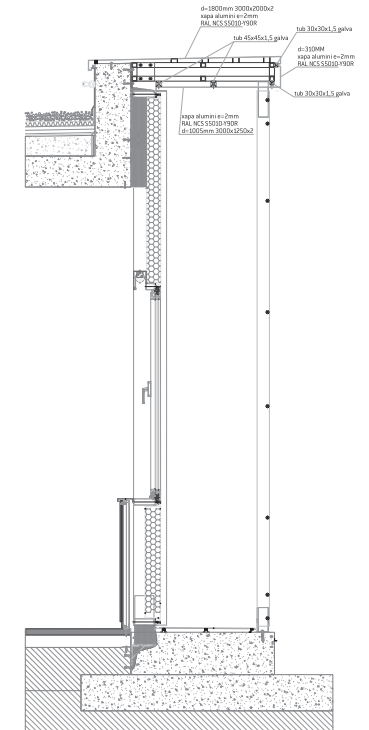



RENOVATION OF SANT HONORAT CLINIC

Barcelona (Spain)

GARCIA FAURA
ARCHITECTURE
IN ALUMINUM,
STEEL AND GLASS

RENOVATION OF SANT HONORAT CLINIC
Barcelona (Spain)



Year of completion
2015

Architect
CPVA Architects

Works surface area
Composite cladding: 1300 m²
Enclosures: 307 m²

Mutua Maz renovated the former Sant Honorat clinic in Barcelona to create a new health centre under the name Clínica Suma. The renovation not only improved the existing services and equipment, but also entailed the construction of a new surgical block with four surgeries, the extension of the diagnostic radiology service and the creation of new post-surgery observation rooms and waiting rooms. In addition, the new Barcelona clinic also completely renovated its exterior appearance, and now boasts a more modern image that is in harmony with the constant transformation of the city.



GARCIA FAURA
ARCHITECTURE
IN ALUMINUM,
STEEL AND GLASS

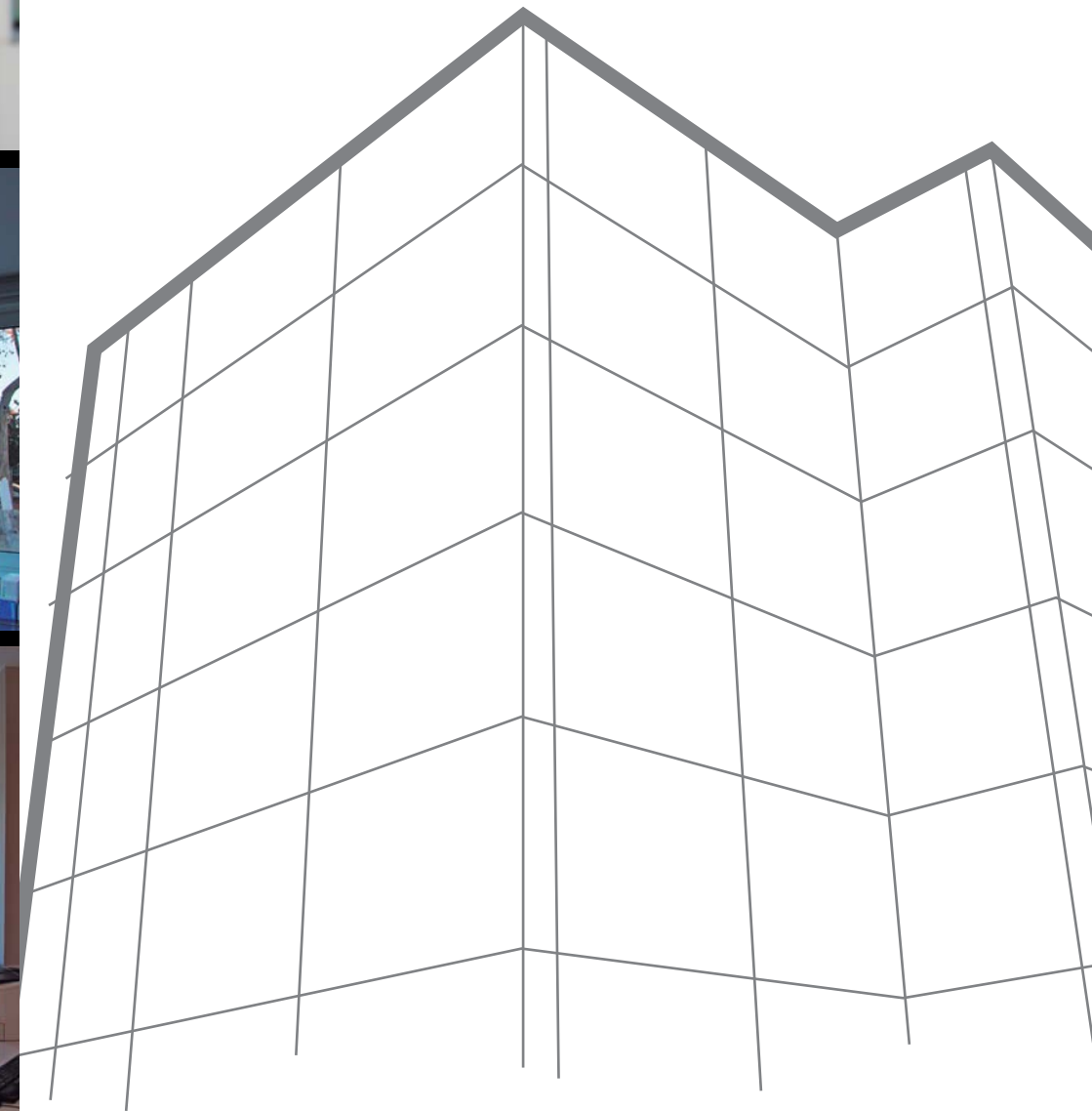



EXTENSION OF THE CHEMICAL INSTITUTE OF SARRIÀ

Barcelona (Spain)

GARCIA FAURA
ARCHITECTURE
IN ALUMINUM,
STEEL AND GLASS

EXTENSION OF THE CHEMICAL INSTITUTE OF SARRIÀ
Barcelona (Spain)



Year of completion
2012

Architect
José Antonio Gardiazabal

Works surface area
Enclosures: 1184 m²

New building for the Economics Faculty of the Chemical Institute of Sarrià, a centre attached to the Ramon Llull University. A sustainable architecture building containing 15 rooms with an average capacity of 60 students; 25 offices for teaching staff, dean's office and administrative services. This new educational building also contains the rooms for the Business Alumni programme, International Relations, Programmes for Executives and a Work Experience Laboratory: A modern and functional building for the teaching activity and academic world.

Most notable is the set of tilted windows located on one of the ends of the facade. It is a space without frameworks, in such a way that the windows and doors are attached to a metal structure. In the interior of the building **GARCIA FAURA** fabricated and installed a large lift window measuring 18 metres wide and 3 metres high divided into 7 sashes, guaranteeing the space outstanding airtightness.

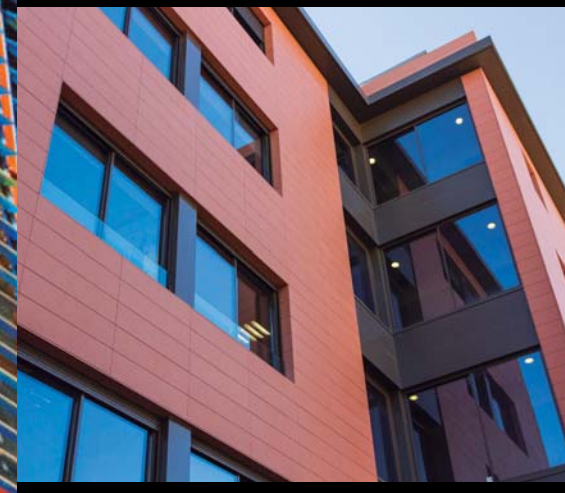

ALÇAT VISTA EXTERIOR

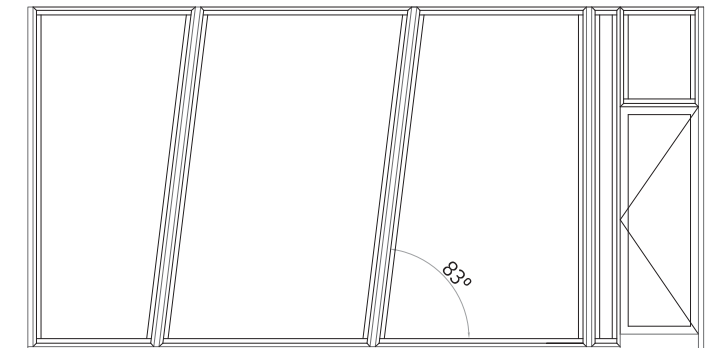

SECCIÓ A-A'

Detall nº1

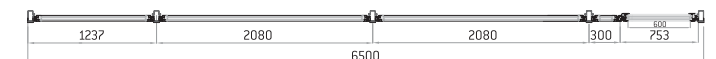

GARCIA FAURA
ARCHITECTURE
IN ALUMINUM,



NEST CELLEX UPC BUILDING

Castelldefels (Spain)

GARCIA FAURA
ARCHITECTURE
IN ALUMINUM,
STEEL AND GLASS

NEST CELLEX UPC BUILDING
Castelldefels (Spain)

Year of completion
2012

Architect
Xavier Farré

Works surface area
Enclosures: 609 m²

Headquarters of the Institute of Photonic Sciences, promoted by the Cellex Foundation, and located in the Mediterranean Technology Park. A building measuring 4000 square metres, notable for its innovative structural design, both on an architectural design level and in terms of work organisation. In this building, some fifty researchers and scientists develop their innovation and development projects in the field of laser and light research.

As a light research centre, the building is committed to the contrast of light and shadows and an exhaustive work of light optimisation using solar protection and other elements. Outside the building a curtain wall has been built with gangways that give an aesthetic appearance to the building, while facilitating maintenance and prevention tasks. A modern building for scientific research.

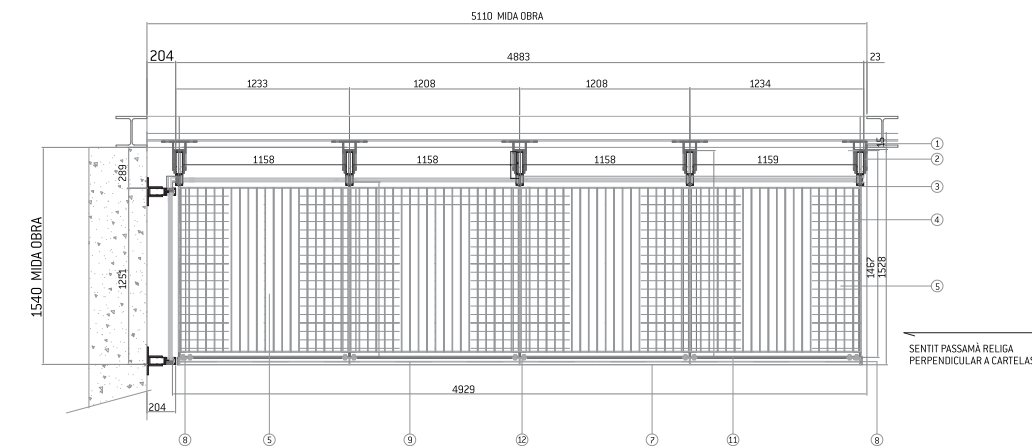
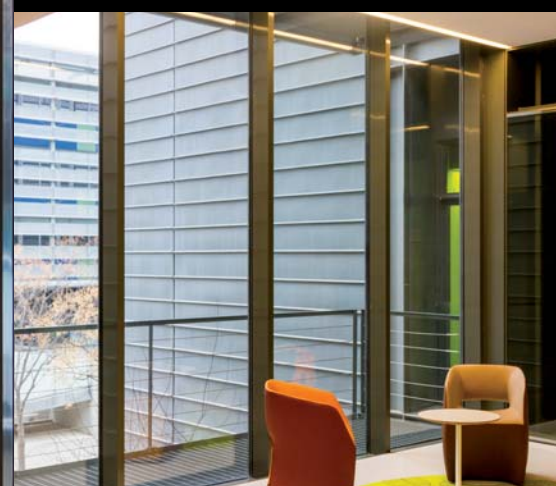

GARCIA FAURA
ARCHITECTURE
IN ALUMINUM,
STEEL AND GLASS



BARCELONA TRADE SHOW

L'Hospitalet de Llobregat (Spain)

GARCIA FAURA
ARCHITECTURE
IN ALUMINUM,
STEEL AND GLASS

BARCELONA TRADE SHOW
L'Hospitalet de Llobregat (Spain)

Year of completion
2007

Architect
Toyo Ito

Designed by the architect Toyo Ito. In one of its pavilions, we highlight the undulating curtain wall formed by a metallic structure hanging from the roof, without mounts. The whole complex is spacious and bright, with large windows sealed to the ground with structural silicone. A lot of coordination involved between the architectural studio and the company, in order to provide the technical solutions necessary to meet the architect's requirements.



DETALLS MUR SENSE MUNTANTS

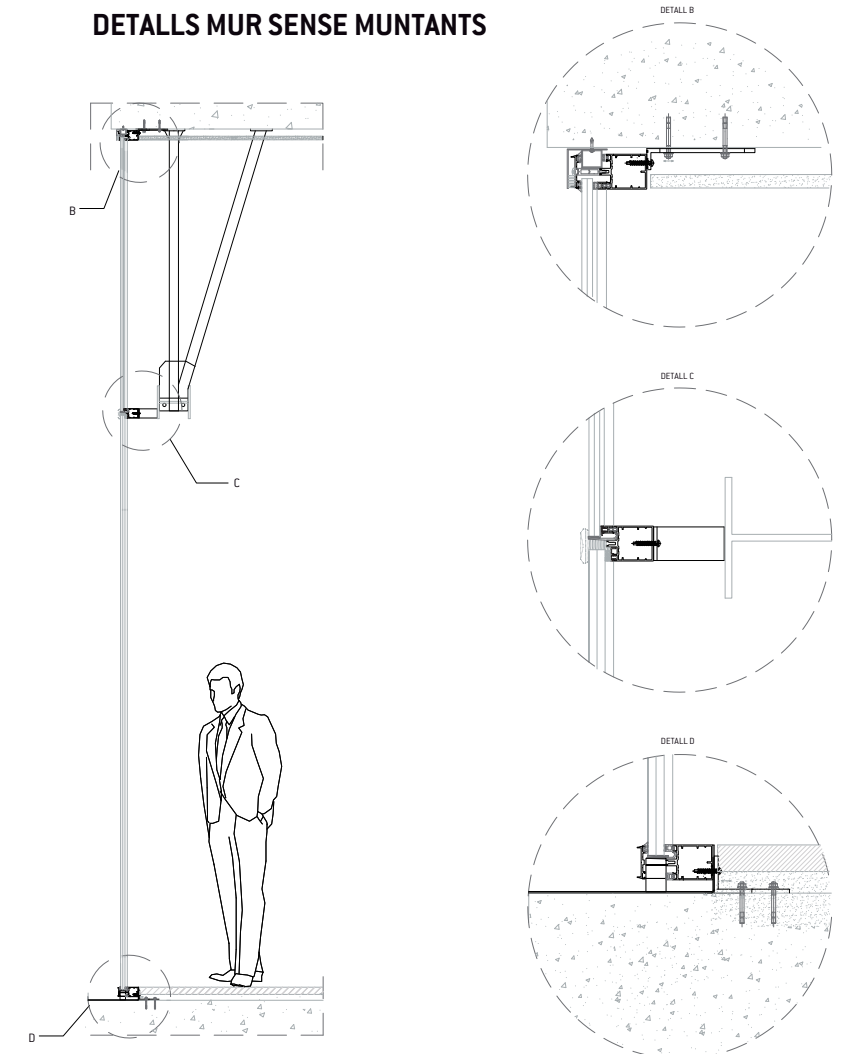

GARCIA FAURA
ARCHITECTURE
IN ALUMINUM,
STEEL AND GLASS



SANT JOAN DE DÉU NUMANCIA HOSPITAL

Barcelona (Spain)

GARCIA FAURA
ARCHITECTURE
IN ALUMINUM,
STEEL AND GLASS

SANT JOAN DE DÉU NUMANCIA HOSPITAL
Barcelona (Spain)



Year of completion
2011

Architect
Estudio CPVA Arquitectes

Works surface area
Enclosures: 980 m²
Veneer cladding: 1278 m²

Building composed of two wings joined by a central structure, measuring a total of 23,000 square metres, and 8 storeys high. The architects organised the facade design based on the interior lighting needs. A ventilated facade system was decided on with windows and doors that would provide rooms with the maximum amount of light, while also maintaining the privacy a building of these characteristics requires. The windows blend perfectly into the weave of vertical and horizontal lines drawn by the facade itself.

One of the most important elements of the building is its exterior appearance, and that is why profiles that would not take away from the facade itself were used. The main feature of the work is a purely architectural window model that is reminiscent of the former corrugated steel joinery. The reduced mass of aluminium seen from the outside helps to give the window a simple but slender line. It guarantees the maximum glazing capacity while providing complete luminosity in the rooms, as set out in the architectural project.

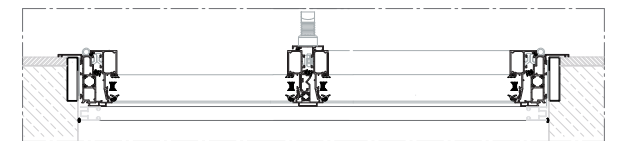
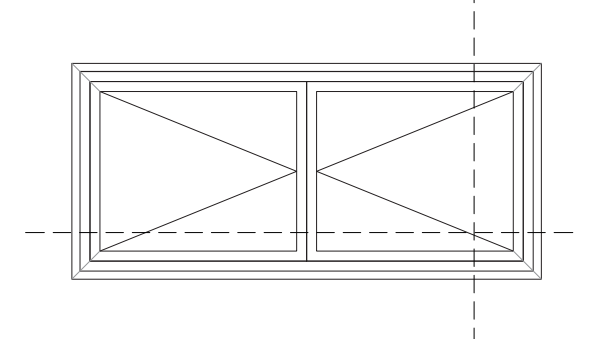
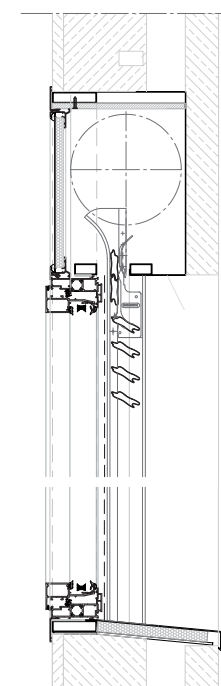
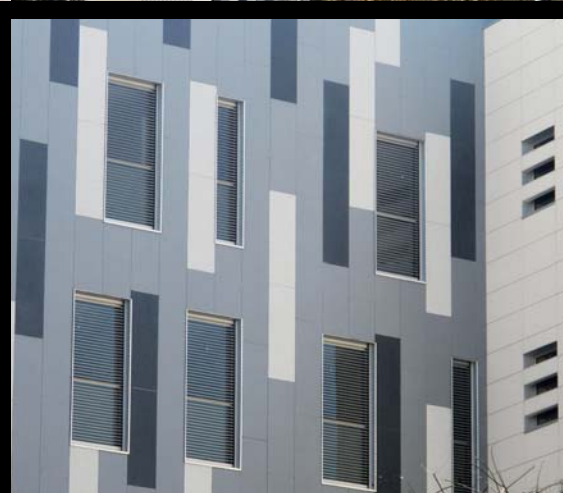

GARCIA FAURA
ARCHITECTURE
IN ALUMINUM,
STEEL AND GLASS



CENTRAL OFFICES RBA EDITORES

Barcelona (Spain)

GARCIA FAURA
ARCHITECTURE
IN ALUMINUM,
STEEL AND GLASS

CENTRAL OFFICES RBA EDITORES

Barcelona (Spain)



Year of completion
2011

Architect
MBM Arquitectes

Works surface area
Enclosures: 4.535 m²

Glass facade: 961 m²

Glass sunshade: 177 m²

Molding: 4.518 ml

Tower with two distinct bodies, projected by the architects Josep Martorell, Oriol Bohigas and David Mackay. All of the façades were made combining different materials to create a flexible surface. Dry façade, presents a structural frame with white aluminum profiles extruded expressly for the construction, based on the architect's design.

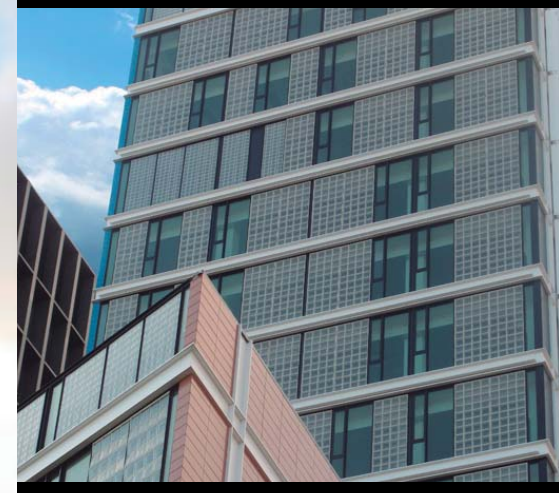

SUBJECCIÓ CANTELLS FORJAT

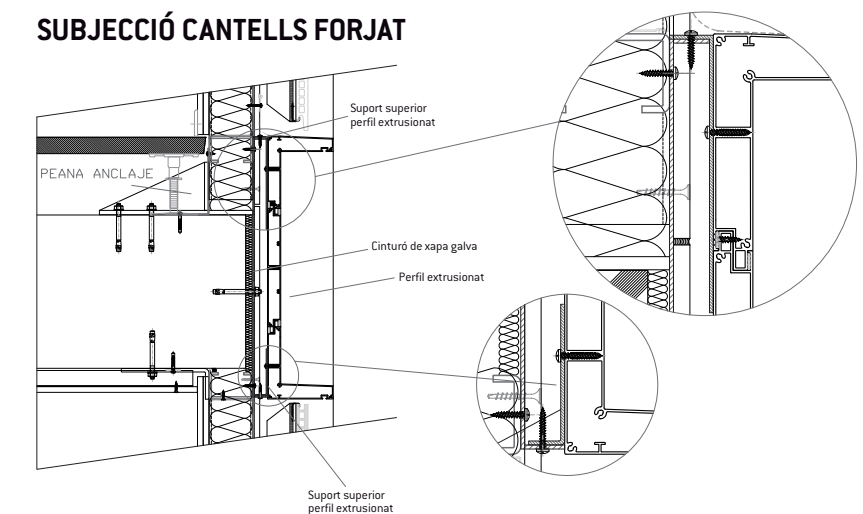

DETALL SUBESTRUCTURA BRISE SOLEIL

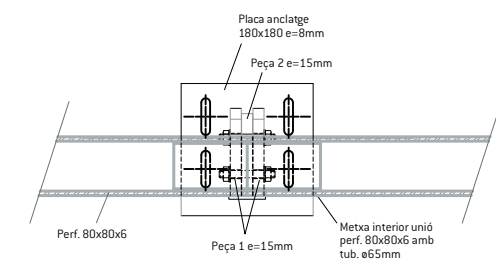
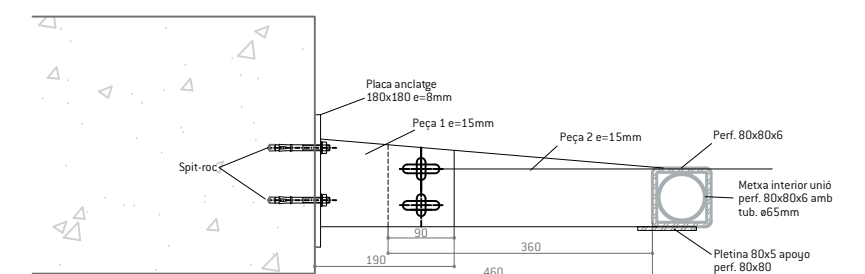

GARCIA FAURA
ARCHITECTURE
IN ALUMINUM,
STEEL AND GLASS



PLACE EUROPE OFFICES

L'Hospitalet de Llobregat (Spain)

GARCIA FAURA
ARCHITECTURE
IN ALUMINUM,
STEEL AND GLASS

PLACE EUROPE OFFICES
L'Hospitalet de Llobregat (Spain)

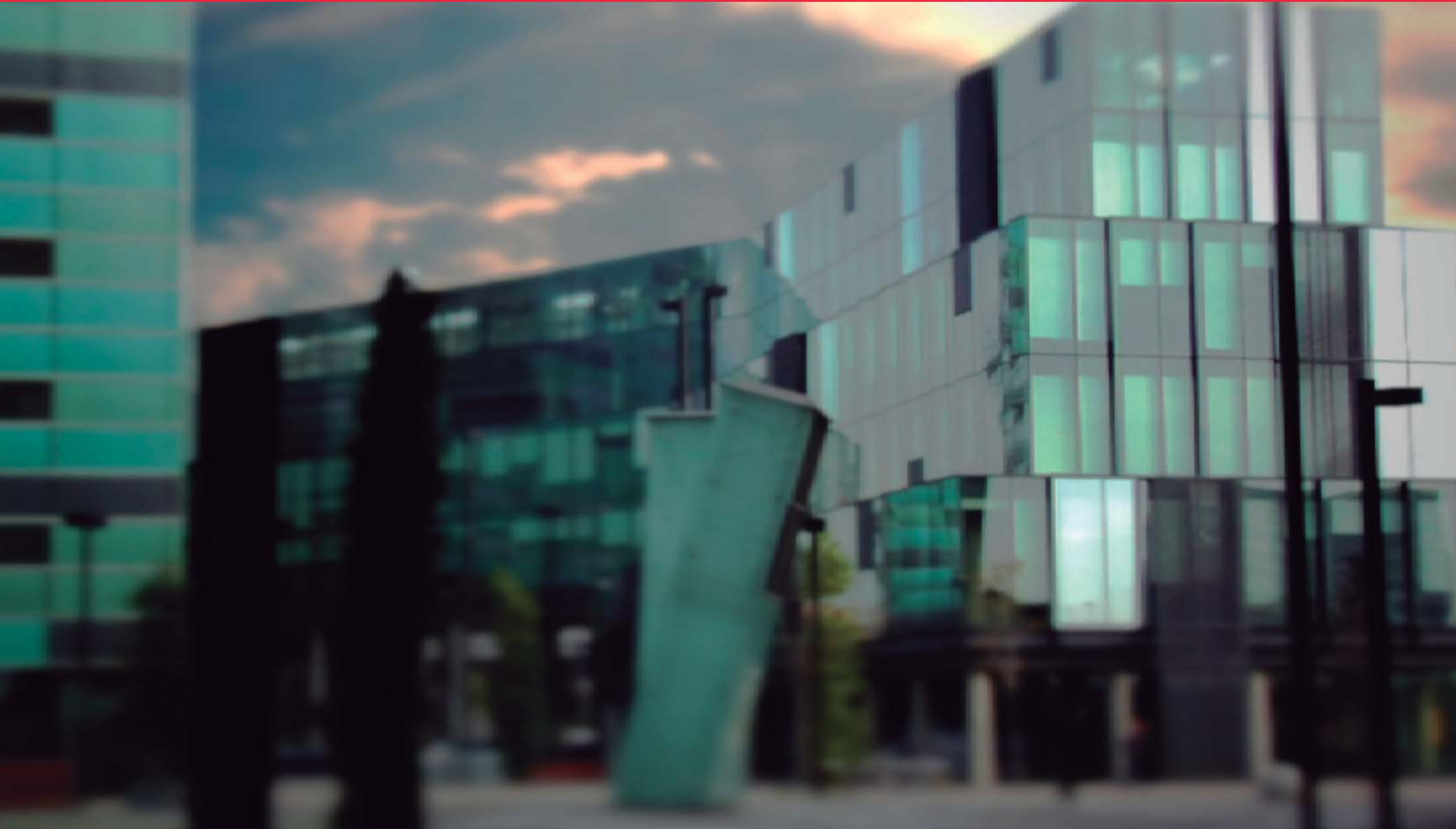

Year of completion
2010

Architect
Albert and David Viaplana

Works surface area
Modular facade: 3666 m²
Enclosures: 243 m²
Railings: 337 m²

Project by the architects Albert and David Viaplana. Glass solutions clearly dominate the exterior appearance, with large solar control glass. It is important to point out that although the facade was not planned as a modular one, it was treated as such and was fabricated in the workshop with all the built-in elements, and was ready to send to the site and be installed.

The particular nature of this building is, obviously, its exterior aesthetic composed of a modular facade graduated around a very unique curved structure. This light facade, treated as a modular wall, was developed by the Departments of Production, Drawing Office and Installation of **GARCIA FAURA**. In this way, each of the modules was fully fabricated in the workshop, ensuring a better quality finish and providing a full guarantee in all the production control processes in the factory. This facilitated a faster and more secure installation on site, aspects which **GARCIA FAURA** considers as very important.

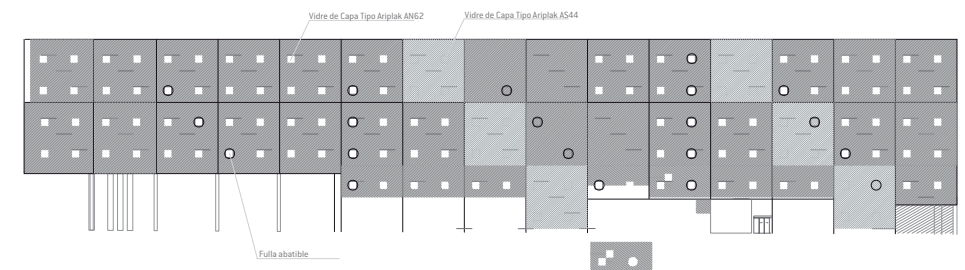
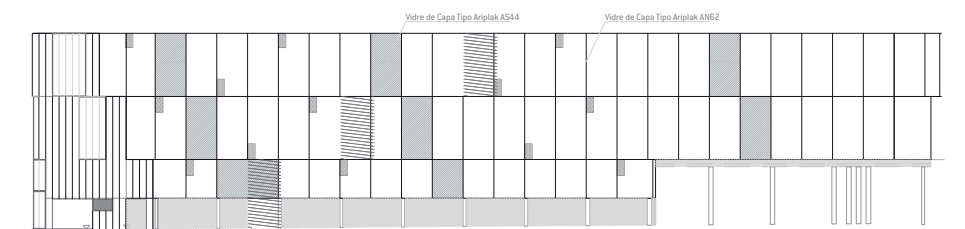

GARCIA FAURA
ARCHITECTURE
IN ALUMINUM,



INBISA 22@ TOWER

Barcelona (Spain)

GARCIA FAURA
ARCHITECTURE
IN ALUMINUM,
STEEL AND GLASS

INBISA 22@ TOWER
Barcelona (Spain)

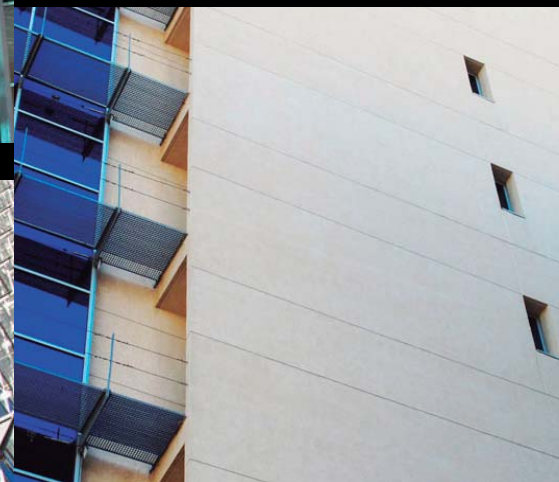

Year of completion
2009

Works surface area
Glass facade: 3.778 m²

Enclosures: 620 m²

Walkways: 500 ml

An office complex arranged into two bodies, the largest of which consists of an isolated tower of four walls and standing 12 floors high. It represents one of the most ambitious real estate projects in the new technological district of Barcelona, with high-level offices totaling an area of more than 12,000 square meters. The key to this building and, by extension, its façade and cladding work has been to achieve the highest standards of quality, efficiency and comfort.

DETALL TALLAFOCS

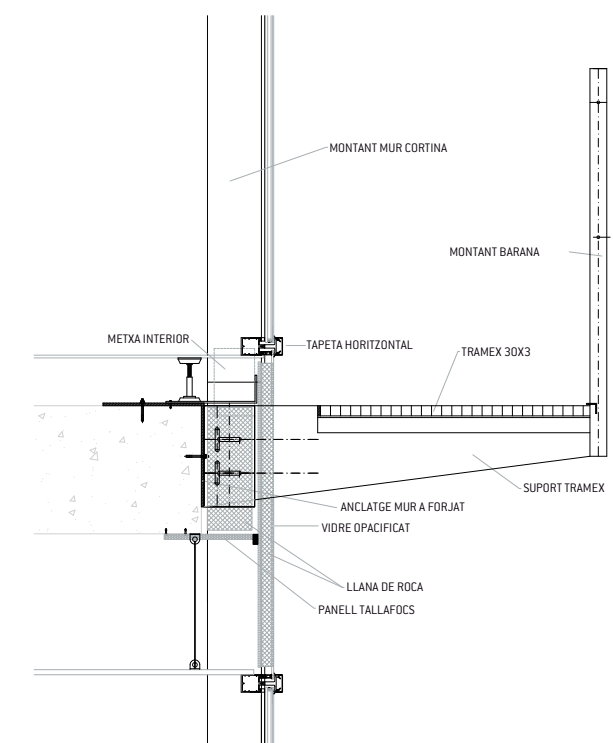

GARCIA FAURA
ARCHITECTURE
IN ALUMINUM,
STEEL AND GLASS



MAS SAURÓ RESIDENCE

Barcelona (Spain)

GARCIA FAURA
ARCHITECTURE
IN ALUMINUM,
STEEL AND GLASS

MAS SAURÓ RESIDENCE
Barcelona (Spain)

Year of completion
2011

Architects
Alfredo Lérica
Pedro Alarcón
Amadeu Matosas

A public residence for disabled people, which situates the functional modules in the centre of the map, and, based on these, establishes the building's other needs: a residential area, an administrative area, workshops, etc. The building blends into its surroundings and seeks to showcase the architectural aesthetics while completely adapting to the topography of the zone. The grouping together of the residential modules, separated by terraces, serves to build suitably sized buildings that blend into the wooded area of Vallvidrera.

GARCIA FAURA fabricated and installed all the windows and doors of this residence, as well as the main skylight, with reinforced posts, extruded specifically for this project. Most notable is the work carried out to overcome any architectural obstacles, related to windows and doors, and also in transitory areas. As such, the usage needs of the designed building were met.



GARCIA FAURA
ARCHITECTURE
IN ALUMINUM,
STEEL AND GLASS

DETALL EPURE T FIXE-PRACT (E:1/1)

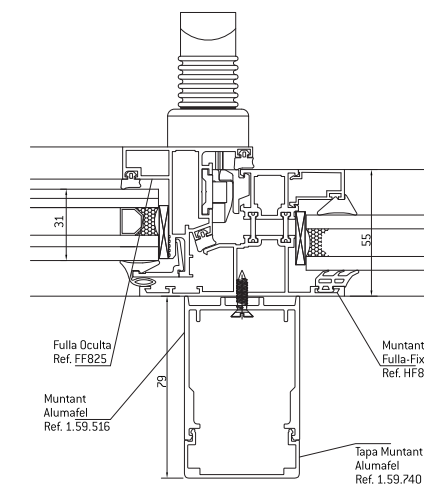

DETALL EPURE T FIXE-FIXE (E:1/1)

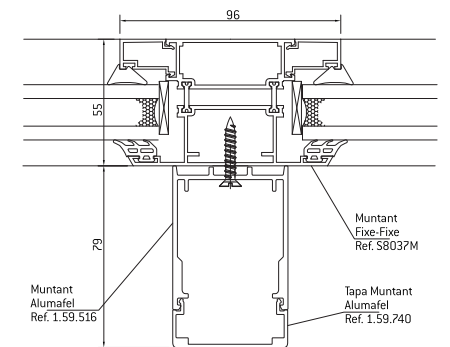



LICEU MUSIC CONSERVATORY

Barcelona (Spain)

GARCIA FAURA
ARCHITECTURE
IN ALUMINUM,
STEEL AND GLASS

LICEU MUSIC CONSERVATORY
Barcelona (Spain)



Year of completion
2009

Architect
Dani Freixes

Works surface area
Enclosures: 585 m²
Composite panel: 2803 m²
Curtain wall: 384 m²

Work by Dani Freixes and the Varis Arquitectes office. Most notable in this work is the glass work built around a unique structure and a large central light shaft, measuring 10 metres in diameter, open to the sky, around which the music rooms and auditoria of the building have been structured.

The starting point of the work is, evidently, its use as a music conservatory. This calls for specific needs in the area of soundproofing, to guarantee the individual work in each room, but also the soundproofing of the whole building with regard to the exterior. To achieve this, the facade was designed in an acoustic studio to reach all the goals defined by the architect. The interior curved glass wall is a notable feature, reminiscent of the keys of a piano, and gives the central area of the building a unique appearance.

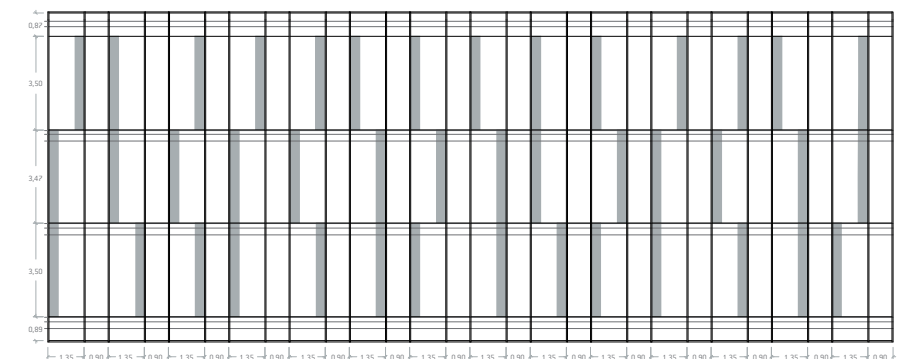
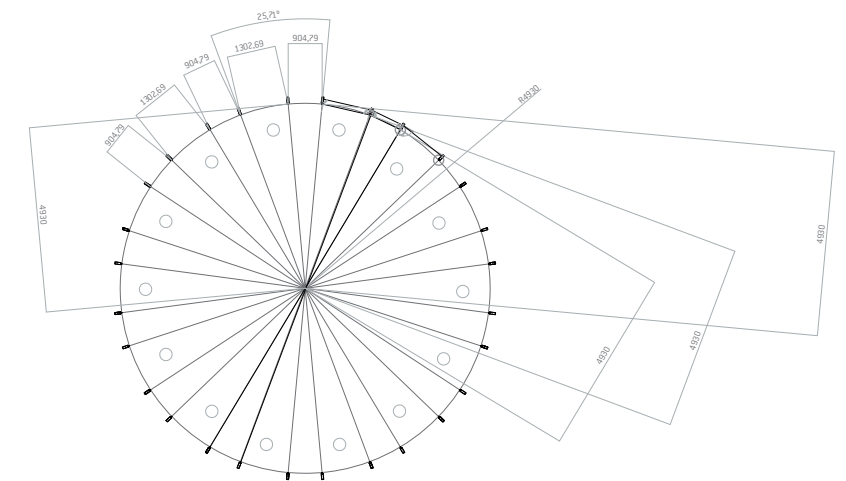

DESENVOLUPAMENT MUR CORTINA PATI

GARCIA FAURA
ARCHITECTURE
IN ALUMINUM,
STEEL AND GLASS



CITY OF JUSTICE

L'Hospitalet de Llobregat (Spain)

GARCIA FAURA
ARCHITECTURE
IN ALUMINUM,
STEEL AND GLASS

CITY OF JUSTICE
L'Hospitalet de Llobregat (Spain)

Year of completion
2009

Architect
David Chipperfield / Estudio b720

Works surface area
Enclosures: 19.893 m²
Railings: 662 m²
Glass atrium: 3.018 m²

Project by the architect David Chipperfield and the studio b720, consisting of 8 interconnected buildings. More than 11,500 casement windows with concealed leaf were built, which become the most outstanding feature of the overall aesthetics of the complex, as well as the heat-resistant metal cladding. The leaf profiles and framework were created especially to be adapted to the project, and include the support itself for the railing, minimizing the visual impact of the complex and creating an image of lightness in the architectural design.

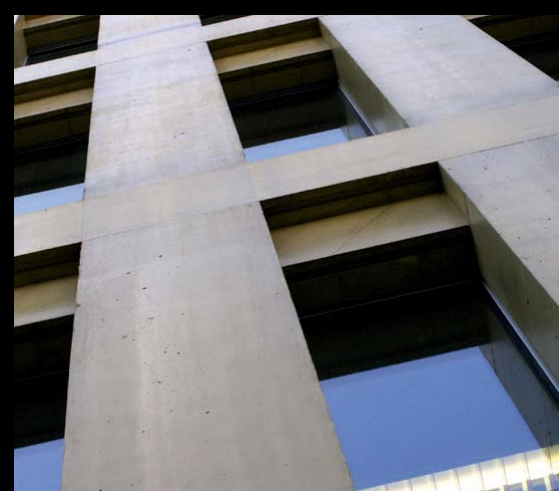

GARCIA FAURA
ARCHITECTURE
IN ALUMINUM,
STEEL AND GLASS

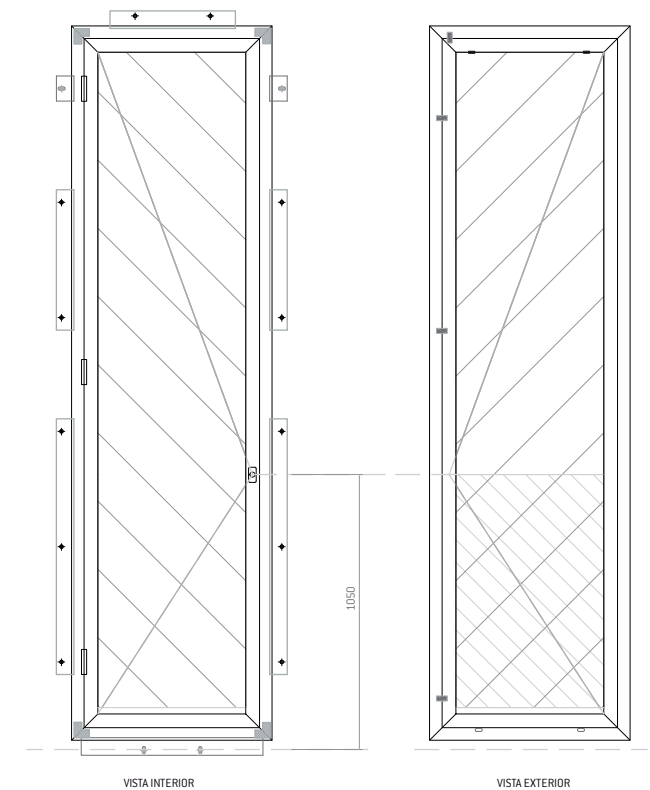



PRISIONS IN SPAIN

Sant Joan de Vilatorrada, Figueres, Tarragona, Pamplona (Spain)

GARCIA FAURA
ARCHITECTURE
IN ALUMINUM,
STEEL AND GLASS

PRISIONS IN SPAIN
Sant Joan de Vilatorrada,
Figueres, Tarragona, Pamplona (Spain)

Years of completion
2008-2012

Specialists in iron and stainless steel for prisons. Manufacture and installation of all gates, cells, partitions and enclosures, determined according to the project's specifications. For this type of project, the production line method implemented in the factory enables the work to progress consistently and at a steady pace, thereby producing a high daily output of units. Our Technical Office assigns its own team of engineers who are responsible for drawing the plans, the production orders and the general coordination with the work.



GARCIA FAURA
ARCHITECTURE
IN ALUMINUM,
STEEL AND GLASS

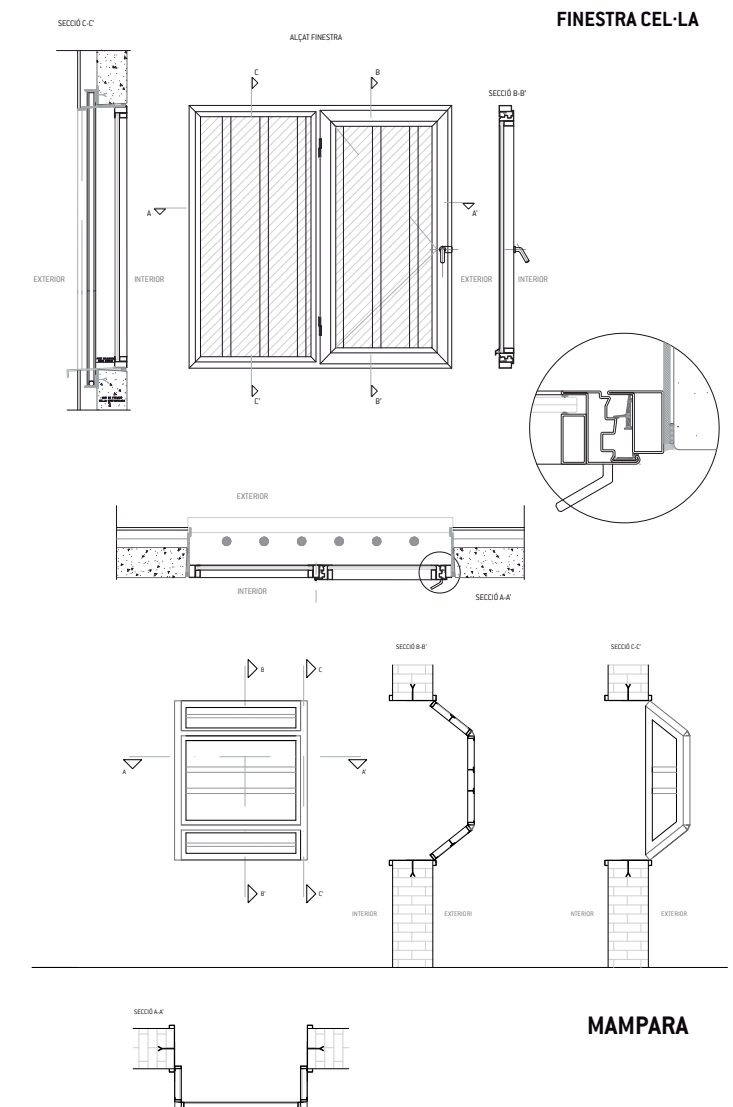

**Thank you for
your trust.
GARCIA FAURA**

Scan this QR code
for more information
about
GARCIA FAURA

